

MAGNA3

Circulator pumps

50/60 Hz



be
think
innovate

GRUNDFOS 

| | |
|-----------------------------------------------------|-----------|
| 1. Product description | 3 |
| Main applications | 3 |
| 2. Type key | 4 |
| 3. Product range | 4 |
| Performance range, MAGNA3 | 5 |
| Performance range, MAGNA3 D single-head operation | 6 |
| Performance range, MAGNA3 D twin-head operation | 7 |
| Pump selection | 8 |
| Operating modes | 11 |
| Control modes | 11 |
| Additional features for control modes | 14 |
| Additional operating modes for multi-pump setup | 16 |
| Readings and settings on the pump | 16 |
| Communication | 19 |
| 4. Operating conditions | 22 |
| General recommendations | 22 |
| Pumped liquids | 22 |
| Differential-pressure and temperature sensor | 23 |
| Electrical data | 23 |
| 5. Construction | 24 |
| Sectional drawing | 25 |
| Material specification | 25 |
| 6. Installation | 26 |
| Mechanical installation | 26 |
| Electrical installation | 26 |
| Cables | 26 |
| Examples of connections | 27 |
| 7. Accessories | 30 |
| Insulating for air-conditioning and cooling systems | 30 |
| CIM modules | 30 |
| Grundfos GO Remote | 31 |
| 8. Curve conditions | 32 |
| Performance curves | 32 |
| QR code on pump nameplate | 33 |
| 9. Performance curves | 34 |
| MAGNA3 40-80 F (N) | 34 |
| 10. Product numbers | 46 |
| MAGNA3 | 46 |
| External sensors | 46 |
| Blanking flange | 46 |
| 11. Further product information | 47 |
| WebCAPS | 47 |
| WinCAPS | 48 |
| GO CAPS | 49 |

1. Product description

The Grundfos MAGNA3 circulator pumps are designed for circulating liquids in the following systems:

- heating systems
- air-conditioning and cooling systems
- domestic hot-water systems.
- ground source heat pump systems
- solar-heating systems.

Duty range

| Data | MAGNA3 (N) Single-head pumps | MAGNA3 D Twin-head pumps |
|-------------------------|-------------------------------------|------------------------------------|
| Maximum flow rate, Q | 346 GPM [78.5 m ³ /h] | 570 GPM [150 m ³ /h] |
| Maximum head, H | 60 ft [18 m] | |
| Maximum system pressure | 175 PSI [1.2 MPa (12 bar)] | |
| Liquid temperature | 14 to 230 F [-10 to +110 °C] | |



TM05 7660 1413

Fig. 1 MAGNA3 pump ranges

Characteristic features

- AUTO_{ADAPT}.
- FLOW_{ADAPT} and FLOW_{LIMIT}.
- Intuitive user interface with TFT display.
- Proportional-pressure control.
- Constant-pressure control.
- Constant-temperature control.
- Built-in Grundfos differential-pressure and temperature sensor.
- Constant-curve duty.
- Max. or min. curve duty.
- Automatic Night Setback.
- Internal motor protection.
- Heat energy meter.
- Work log history.
- Insulating shells supplied with single-head pumps for heating systems.
- Large temperature range where the liquid temperature and the ambient temperature are independent of each other.

Benefits

- Unparalleled energy efficiency.
- Safe selection.
- Simple installation.
- Maintenance free.
- Guided installation.
- Simple assisted troubleshooting.
- Easy system optimization.
- Multi-pump function.
- External control and monitoring enabled via add-on modules.
- No external motor protection required.
- The complete range is available for a maximum system pressure of 175 PSI [12 bar].

Main applications

Heating systems

- Main pump
- mixing loops
- domestic hot water
- heating surfaces
- air-conditioning surfaces.

The MAGNA3 circulator pumps are designed for circulating liquids in systems with variable flows where it is desirable to optimize the setting of the pump duty point, thus reducing energy costs.

The pump is especially suitable for installation in existing systems where the differential pressure across the pump is too high in periods with reduced flow demand. The pump is also suitable for new systems where automatic adjustment of pump head to actual flow demand is desired, without using expensive bypass valves or similar components.

Furthermore, the pump is suitable for systems with hot-water priority as an external signal can immediately force the pump to operate according to the max. curve, for example in solar-heating systems.

2. Type key

| Code | Example | MAGNA3 | (D) | 100 | -120 | (F) | (N) | 360 |
|------|--------------------------------------------------------------|--------|-----|-----|------|-----|-----|-----|
| | Type range MAGNA3 | | | | | | | |
| D | Single-head pump Twin-head pump | | | | | | | |
| | Nominal diameter (DN) of suction and discharge ports [mm] | | | | | | | |
| | Maximum head [dm] | | | | | | | |
| F | Pipe connection Flange | | | | | | | |
| N | Pump housing material Cast iron Stainless steel | | | | | | | |
| | Port-to-port length [mm] | | | | | | | |

3. Product range

| Single-head pump | Cast Iron | | Stainless steel | |
|---------------------|-----------|-----------|-----------------|-----------|
| | 115 V | 208-230 V | 115 V | 208-230 V |
| MAGNA3 40-80 F (N) | • | • | • | • |
| MAGNA3 40-120 F (N) | • | • | • | • |
| MAGNA3 40-180 F (N) | • | • | • | • |
| MAGNA3 50-80 F (N) | • | • | • | • |
| MAGNA3 50-150 F (N) | • | • | • | • |
| MAGNA3 65-120 F (N) | • | • | • | • |
| MAGNA3 65-150 F (N) | | • | | • |
| MAGNA3 80-100 F | | • | | • |
| MAGNA3 100-120 F | | • | | • |

| Dual-head pump | Cast Iron | | Stainless steel | |
|--------------------|-----------|-----------|-----------------|-----------|
| | 115 V | 208-230 V | 115 V | 208-230 V |
| MAGNA3 D 65-150 F | | • | | |
| MAGNA3 D 80-100 F | | • | | |
| MAGNA3 D 100-120 F | | • | | |

Performance range, MAGNA3

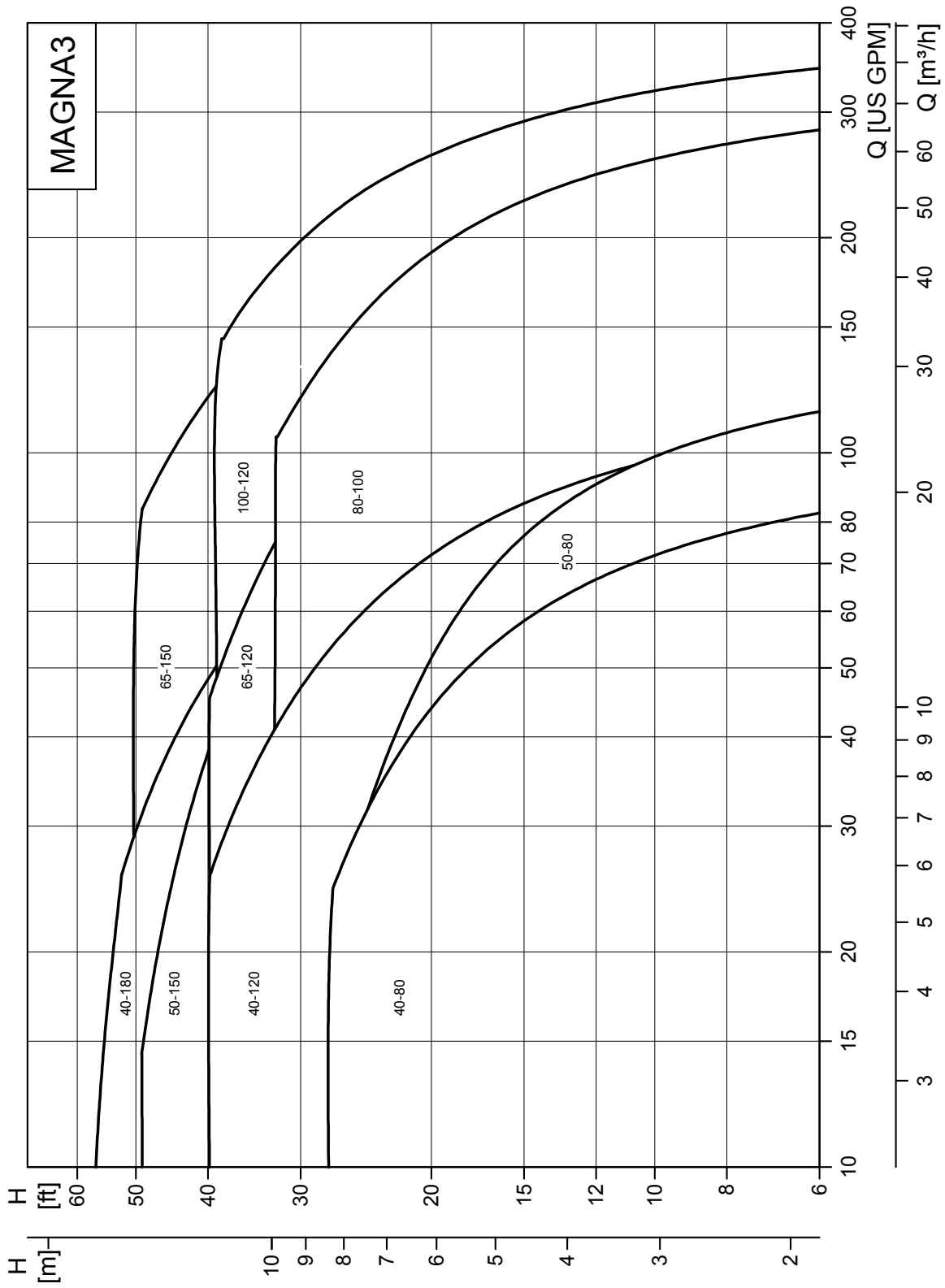

Fig. 2 Performance range, MAGNA3

TM05 7654 1413

Performance range, MAGNA3 D single-head operation

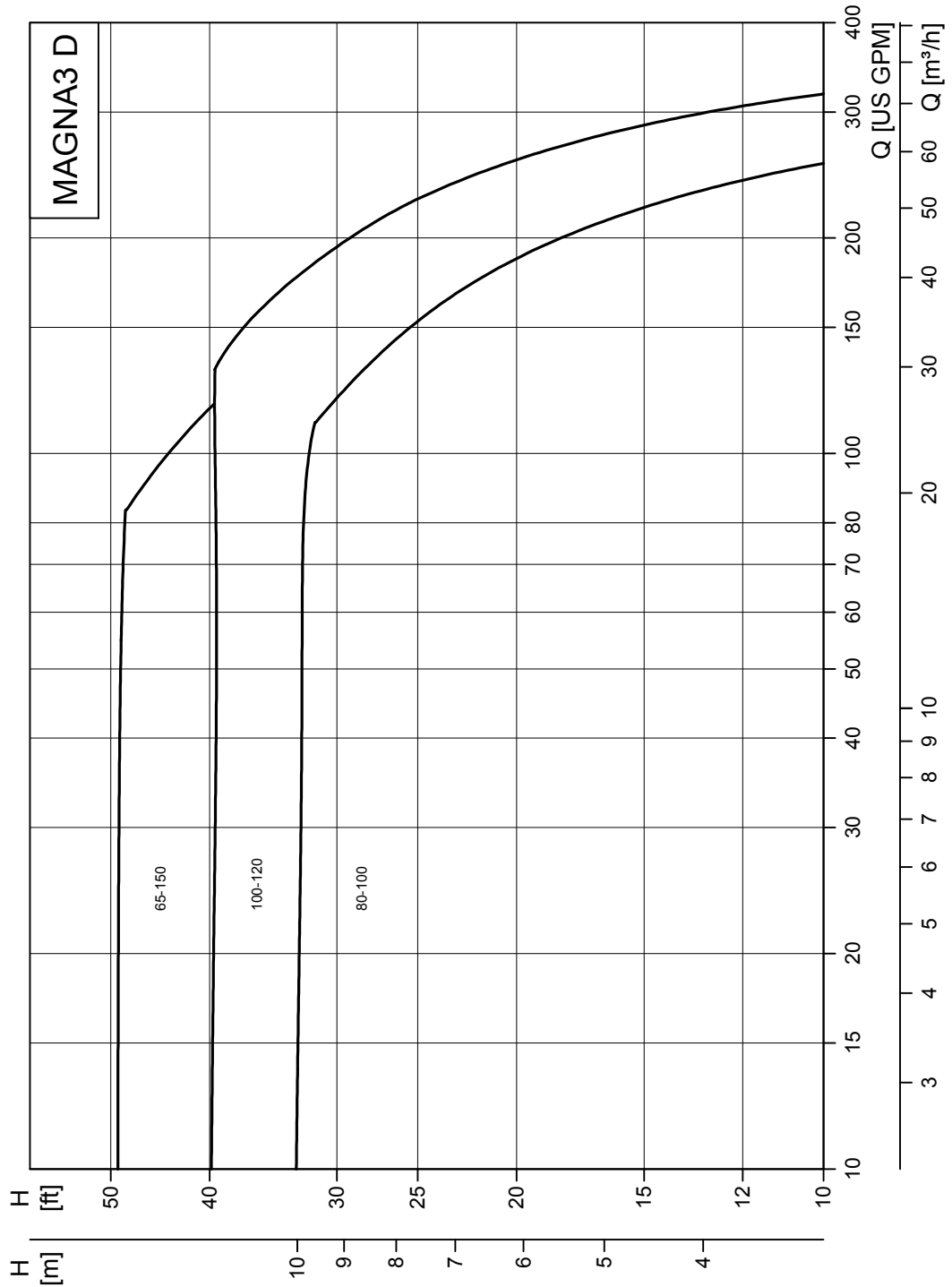

Fig. 3 Performance range, MAGNA3 D single-head operation

TM05 7655 1413

Performance range, MAGNA3 D twin-head operation

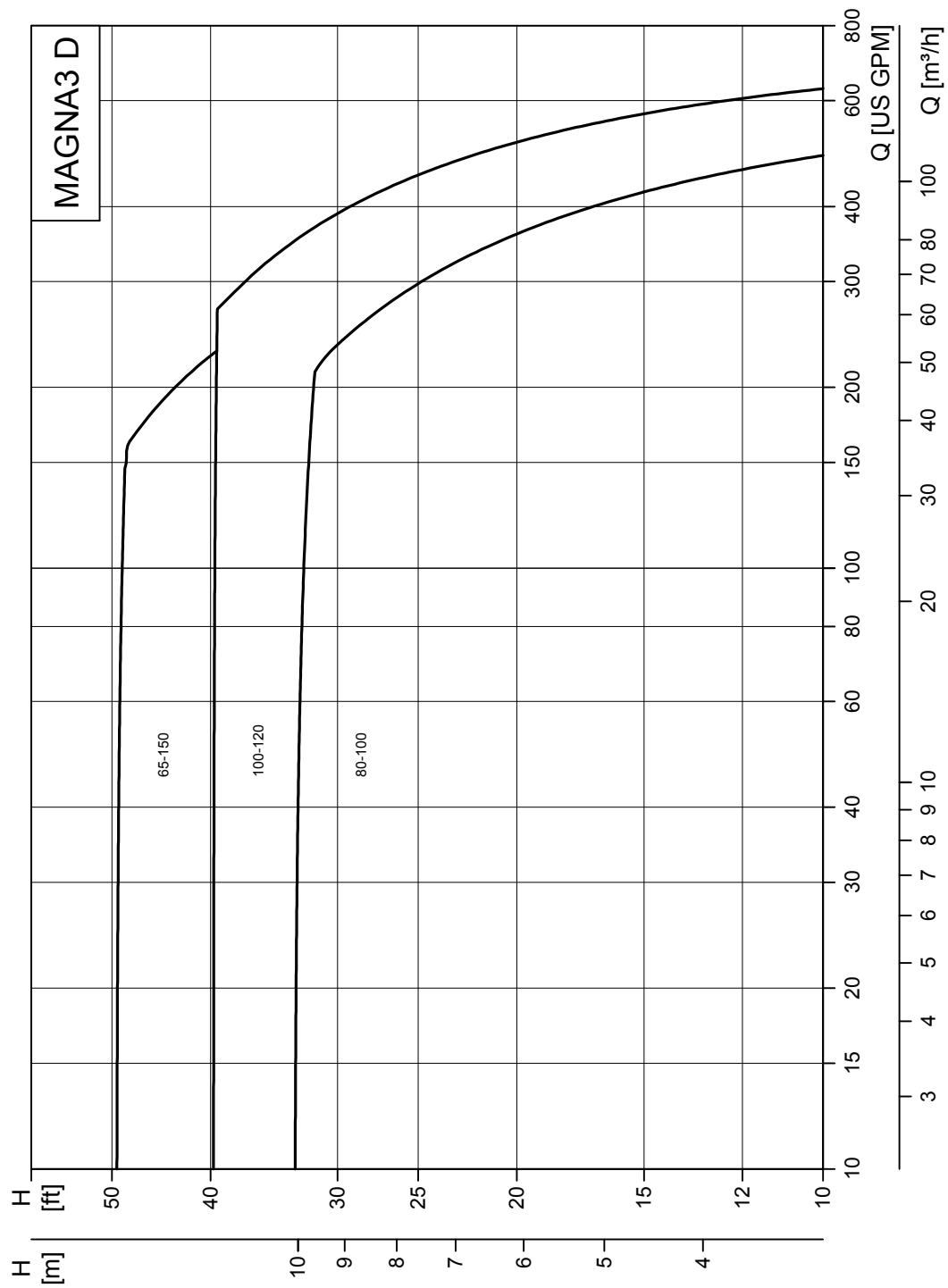

Fig. 4 Performance range, MAGNA3 D twin-head operation

TM05 3938 1812

Pump selection

Frequently, pumps are selected based on a maximum flow and pressure loss in a system as well as peak efficiency of the pump. For circulators in variable demand systems such as a heating system where the heat load varies with the season and time of day it is more optimal to select a pump for this varying demand rather than one specific duty point.

The MAGNA3 has been optimized for variable demand systems. For variable loads, when possible it is most ideal to size and select the pump such that the maximum flow and pressure required is on the right hand side of the pump performance curve.

This enables the pump to have higher efficiency at partial load and allows the pumps to slow down more at these partial loads yielding significant energy savings.

Pump size

The system characteristic is used together with the pump's performance curve for sizing and correct pump selection.

The selection of pump size should be based on the following:

- required maximum flow
- maximum pressure loss in the system.

Refer to the system characteristics to determine the duty point. See fig. 5.

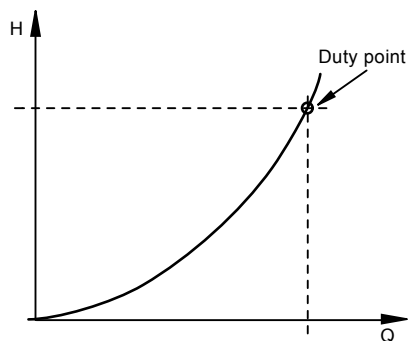

Fig. 5 System characteristic

Operating conditions

When selecting a pump, always verify the operating conditions are fulfilled, Refer to "Operating conditions" on page 22 for:

- liquid quality and temperature
- ambient conditions
- minimum inlet pressure
- maximum operating pressure.

Control modes

- $AUTO_{ADAPT}$ (factory setting): Is suitable for most installations. Auto adapt is proportional pressure control where the pump sets and adapts its own set point based on maximum system conditions.

- $FLOW_{ADAPT}$, $FLOW_{LIMIT}$: in systems where a flow limitation is required.
- Proportional-pressure control in systems with considerable pressure loss variation in relation to large flow variations; ie if more than 50 % of pressure loss is due to friction loss in the pipe system
- Constant-pressure control in systems with insignificant pressure loss variation in relation to large flow variations; ie if less than 50 % of pressure loss is due to friction loss in the pipe system
- Constant-temperature control in heating systems with a fixed system characteristic, for example domestic hot-water systems.
- Constant-curve duty.

Communication

The Grundfos CIM modules (CIM = Communication Interface Module) enable the MAGNA3 to connect to standard fieldbus networks, offering substantial benefits:

- complete process control and monitoring
- modular design, prepared for future requirements
- based on standard functional profiles
- simple configuration and easy installation
- open communication standards
- reading warning and alarm indications.

For further details, see section "CIM modules" on page 30.

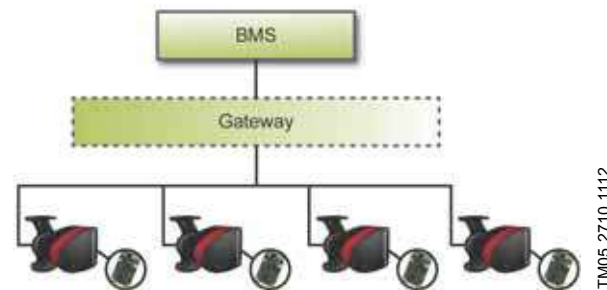

Fig. 6 Example of typical building management system (BMS)

Note: A gateway is a device that facilitates the transfer of data between two different networks based on different communication protocols.

Selection of control mode

System application

Select this control mode

Recommended for most heating systems, especially in systems with relatively large pressure losses in the distribution pipes. See description under proportional pressure.

In replacement situations where the proportional-pressure duty point is unknown.

The duty point has to be within the $AUTO_{ADAPT}$ operating range. During operation, the pump automatically makes the necessary adjustment to the actual system characteristic.

This setting ensures minimum energy consumption and noise level from valves, which reduces operating costs and increases comfort.

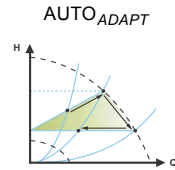

The $FLOW_{ADAPT}$ control mode is a combination of $AUTO_{ADAPT}$ and $FLOW_{LIMIT}$.

This control mode is suitable for systems where a maximum flow limit, $FLOW_{LIMIT}$, is desired. The pump continuously monitors and adjusts the flow, thus ensuring that the selected $FLOW_{LIMIT}$ is not exceeded.

Main pumps in boiler applications where a steady flow through the boiler is required. No extra energy is used for pumping too much liquid into the system.

In systems with mixing loops, the control mode can be used to control the flow in each loop.

Benefits:

- The dimensioned flow for each zone (required heat energy) is determined by the flow from the pump. This value can be set precisely in the $FLOW_{ADAPT}$ control mode without the use of pump throttling valves.
- When the flow is set lower than the balancing valve setting, the pump will ramp down instead of losing energy by pumping against a balancing valve.
- Cooling surfaces in air-conditioning systems can operate at high pressure and low flow.

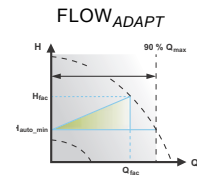

In systems with relatively large pressure losses in the distribution pipes.

- Two-pipe heating systems with:
 - very long distribution pipes
 - strongly throttled pipe balancing valves
 - differential-pressure regulators
 - large pressure losses in those parts of the system through which the total quantity of water flows (for example boiler, heat exchanger and distribution pipe up to the first branching).
- Primary circuit pumps in systems with large pressure losses in the primary circuit.
- Air-conditioning systems with
 - heat exchangers (fan coils)
 - cooling ceilings
 - cooling surfaces.

Proportional pressure

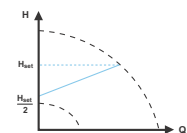

In systems with relatively small pressure losses in the distribution pipes.

- Two-pipe heating systems with:
 - small pressure losses in those parts of the system through which the total quantity of water flows (for example boiler, heat exchanger and distribution pipe up to the first branching) or
 - modified to a high differential temperature between flow pipe and return pipe (for example district heating).
- Underfloor heating systems with control valves.
- One-pipe heating systems with control valves or pipe balancing valves.
- Primary circuit pumps in systems with small pressure losses in the primary circuit.

Constant pressure

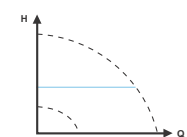

In heating systems with a fixed system characteristic, for example domestic hot-water systems, the control of the pump according to a constant return-pipe temperature may be relevant.

$FLOW_{LIMIT}$ can be used with advantage to control the maximum circulation flow.

Constant temperature

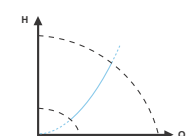

System application**Select this control mode**

If an external controller is installed, the pump is able to change from one constant curve to another, depending on the value of the external signal.

The pump can also be set to operate according to the max. or min. curve, like an uncontrolled pump:

- The max. curve mode can be used in periods in which a maximum flow is required. This operating mode is for instance suitable for hot-water priority.
- The min. curve mode can be used in periods in which a minimum flow is required. This operating mode is for instance suitable for manual night setback if Automatic Night Setback is not desired.

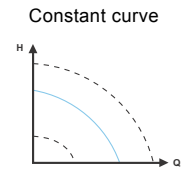

In systems with pumps operating in parallel.

The multi-pump function enables the control of single-head pumps connected in parallel (two pumps) and twin-head pumps without the use of external controllers. The pumps in a multi-pump system communicate with each other via the wireless GENlair connection.

"Assist" menu
Multi-pump setup

Operating modes

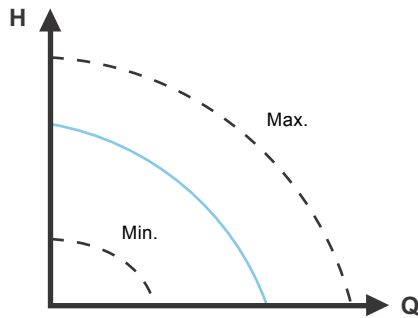

Fig. 7 Max. or min. curves

Normal: The pump runs according to the selected control mode.

Note: The control mode and setpoint can be selected even if the pump is not running in "Normal" mode.

Stop: The pump stops.

Min.: The min. curve mode can be used in periods in which a minimum flow is required.

This operating mode is for instance suitable for manual night setback if Automatic Night Setback is not desired.

Max.: The max. curve mode can be used in periods in which a maximum flow is required.

This operating mode is for instance suitable for hot-water priority.

The operating modes can be selected directly by use of the built-in digital inputs. See section [Digital inputs](#), page 28.

Control modes

Factory setting

The pumps have been factory-set to $AUTO_{ADAPT}$ without Automatic Night Setback.

The setpoint has been factory-set to half of the maximum pump head.

The factory setting is suitable for most installations.

$AUTO_{ADAPT}$

Recommended for most heating systems.

During operation, the pump automatically makes the necessary adjustment to the actual system characteristic.

This setting ensures minimum energy consumption and noise level from valves, which reduces operating costs and increases comfort.

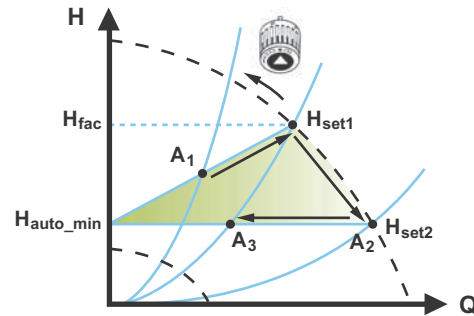

Fig. 8 $AUTO_{ADAPT}$ control

Note: Manual setting of the setpoint is not possible.

When the $AUTO_{ADAPT}$ control mode has been enabled, the pump will start with the factory setting, $H_{fac} = H_{set1}$, corresponding to approx. 55 % of its maximum head, and then adjust its performance to A_1 . See fig. 8.

When the pump registers a lower head on the max. curve, A_2 , the $AUTO_{ADAPT}$ function automatically selects a correspondingly lower control curve, H_{set2} . If the valves in the system close, the pump adjusts its performance to A_3 .

- A_1 : Original duty point.
- A_2 : Lower registered head on the max. curve.
- A_3 : New duty point after $AUTO_{ADAPT}$ control.
- H_{set1} : Original setpoint setting.
- H_{set2} : New setpoint after $AUTO_{ADAPT}$ control.
- H_{fac} : See section [Setting values for control modes \(Single-head operation\)](#), page 15.
- H_{auto_min} : A fixed value of 1.5 m.

The $AUTO_{ADAPT}$ control mode is a form of proportional-pressure control where the control curves have a fixed origin, H_{auto_min} .

The $AUTO_{ADAPT}$ control mode has been developed specifically for heating systems and is not recommended for air-conditioning and cooling systems.

FLOW_{ADAPT}

The typical pump selection is based on required flow and calculated pressure losses. Pumps are often oversized.

To adjust for "oversized" pumps, valves are typically used to increase the resistance and thus reduce the flow. The FLOW_{ADAPT} function reduces the need for a pump throttling valve.

Note: This function cannot eliminate the need for balancing valves in heating systems.

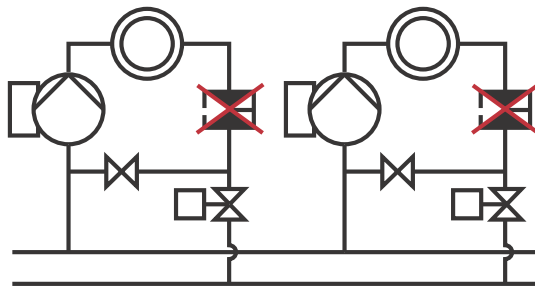

TM05 2685 1212

Fig. 9 Reduced need for a pump throttling valve

The FLOW_{ADAPT} control mode combines a control mode and a function:

- The pump is running AUTO_{ADAPT}.
- The flow will never exceed a selected FLOW_{LIMIT} value, which reduces the need for a pump throttling valve connected in series with the pump.

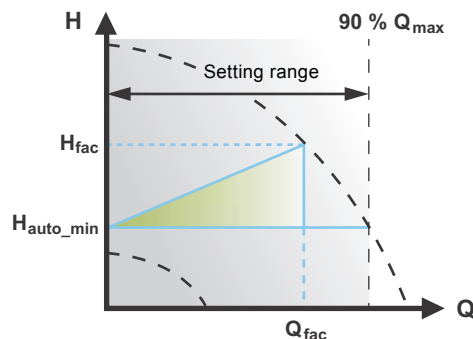

TM05 3334 1312

Fig. 10 FLOW_{ADAPT} control

When FLOW_{ADAPT} is selected, the pump will run AUTO_{ADAPT} and ensure that the flow never exceeds the entered FLOW_{LIMIT} value.

The setting range for the FLOW_{LIMIT} is 25 to 90 % of the Q_{max} of the pump.

The factory setting of the FLOW_{LIMIT} is the flow where the AUTO_{ADAPT} factory setting meets the max. curve. See fig. 10.

Note: Do not set the FLOW_{LIMIT} lower than the dimensioned duty point.

Proportional pressure

This control mode is used in systems with relatively large pressure losses in the distribution pipes. The head of the pump will increase proportionally to the flow in the system to compensate for the large pressure losses in the distribution pipes. The setpoint can be set with an accuracy of 0.1 metre.

The head against a closed valve is half the setpoint H_{set}.

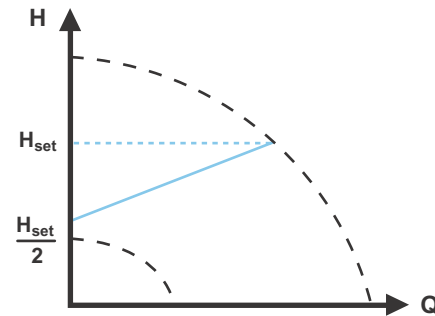

TM05 2448 1212

Fig. 11 Proportional-pressure control

Constant pressure

We recommend this control mode in systems with relatively small pressure losses.

The pump head is kept constant, independent of the flow in the system.

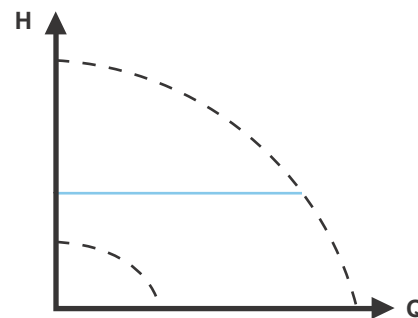

TM05 2449 0312

Fig. 12 Constant-pressure control

Constant temperature

In heating systems with a fixed system characteristic, for example domestic hot-water systems, the control of the pump according to a constant return-pipe temperature is relevant.

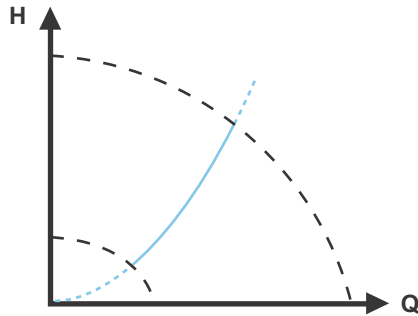

Fig. 13 Constant-temperature control

If the pump is installed in the return pipe of the system, the internal temperature sensor can be used. In this case, the pump must be installed as close as possible to the consumer (radiator, heat exchanger, etc.).

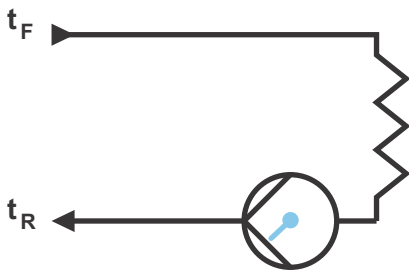

Fig. 14 Pump with internal sensor

Temperature sensor

If the pump is installed in the flow pipe, an external temperature sensor must be installed in the return pipe of the system. See fig. 13. The sensor must be installed as close as possible to the consumer (radiator, heat exchanger, etc.).

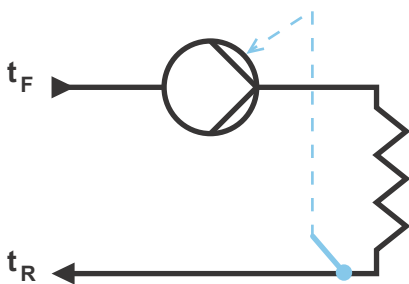

Fig. 15 Pump with external sensor

Differential Temperature

This control mode ensures a constant differential temperature drop across a heating system. The pump should be installed in the flow pipe so the built-in sensor measures the fluid temperature going out to the load. An external temperature sensor must be installed in the system to measure the fluid temperature returning from the heating load. In this mode, the pump will maintain a constant temperature differential between the pump and the external sensor. See figure 16 and 17.

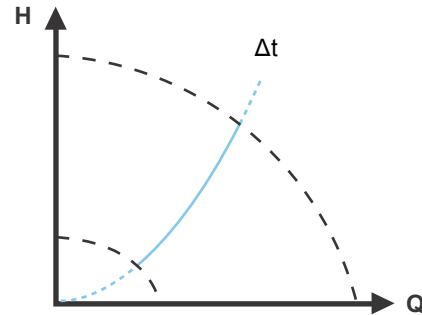

Fig. 16 Differential-temperature control

Temperature Sensor

With the pump installed in the flow pipe, an external temperature sensor may be installed in the return pipe of the system. The sensor should be installed as close to the consumer (radiator, heat exchanger, etc.). The pump can be then set to maintain a constant temperature drop between the integrated temperature sensor in the pump and the external temperature sensor installed in the system.

Note This mode requires use of the GRUNDFOS GO to adjust the Kp and Ti values for temperature control for the specific system.

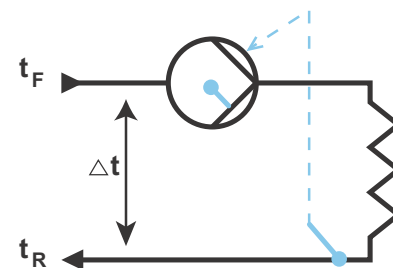

Fig. 17 Pump with external sensor

Constant curve

The pump can be set to operate according to a constant curve, like an uncontrolled pump. See fig. 18. The desired speed can be set in % of maximum speed in the range from 25 to 100 %.

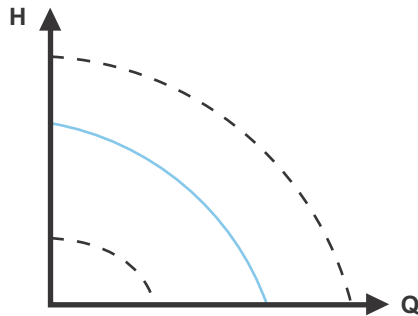

Fig. 18 Constant-curve duty

The pump can also be set to operate according to a selected curve.

Additional features for control modes

The MAGNA3 offers additional features for the control modes to meet specific demands.

FLOW_{LIMIT}

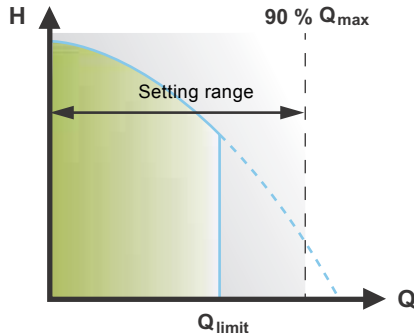

Fig. 19 FLOW_{LIMIT}

The FLOW_{LIMIT} function offers the possibility of limiting the maximum flow delivered by the pump.

The FLOW_{LIMIT} function can be enabled when the pump is in one of the following control modes:

- proportional pressure
- constant pressure
- constant temperature
- constant curve.

In the flow range between 0 and Q_{\max} , the pump will run according to the selected control mode.

When Q_{\max} is reached, the FLOW_{LIMIT} function will reduce the pump speed to ensure that the flow never exceeds the FLOW_{LIMIT} set, no matter if the system requires a higher flow due to a reduced resistance in the system. See fig. 20, 21 or 22.

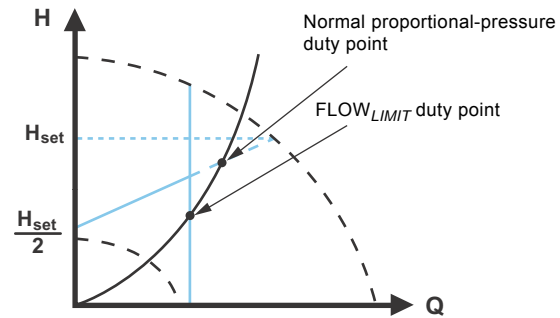

Fig. 20 Proportional-pressure control with FLOW_{LIMIT}

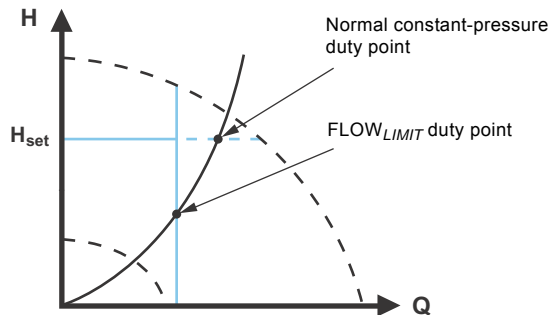

Fig. 21 Constant-pressure control with FLOW_{LIMIT}

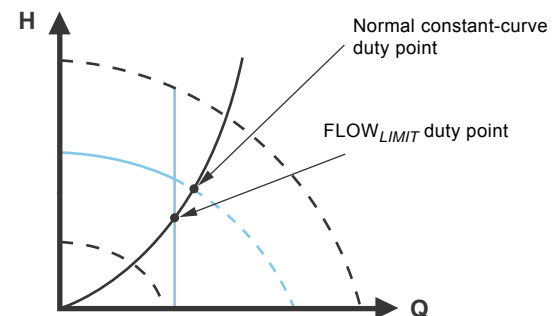

Fig. 22 Constant curve with FLOW_{LIMIT}

Automatic Night Setback

Once Automatic Night Setback has been enabled, the pump automatically changes between normal duty and night setback (duty at low performance).

When Automatic Night Setback has been enabled, the pump will run on the min. curve.

Changeover between normal duty and night setback depends on the flow-pipe temperature.

The pump automatically changes over to night setback when the built-in sensor registers a flow-pipe temperature drop of more than 18 °F to 27 °F [10 to 15 °C] within approx. two hours. The temperature drop must be at least 1.8 °F/min [0.1 °C/min].

Changeover to normal duty takes place without a time lag when the temperature has increased by approx. 18 °F [10 °C].

Note: Automatic Night Setback cannot be enabled when the pump is in constant-curve mode.

Setting values for control modes (Single-head operation)

The setting values for $FLOW_{ADAPT}$ and $FLOW_{LIMIT}$ are indicated as percent of Q_{max} .

| Pump type | $AUTO_{ADAPT}$ | Q_{max} | $FLOW_{ADAPT} / FLOW_{LIMIT}$ | | |
|---------------------------|----------------|-----------------|-------------------------------|-----------------|-----------------|
| | H_{fac} | | Q_{fac} | $Q_{min} 25\%$ | $Q_{max} 90\%$ |
| | ft [m] | gpm [m^3/h] | gpm [m^3/h] | gpm [m^3/h] | gpm [m^3/h] |
| MAGNA3 40-80 F (N) | 14.8 [4.5] | 94.7 [21.5] | 57.2 [13] | 23.8 [5.4] | 85.4 [19.4] |
| MAGNA3 40-120 F (N) | 21.3 [6.5] | 112.2 [25.5] | 70.4 [16] | 28.2 [6.4] | 101.2 [23] |
| MAGNA3 40-180 F (N) | 31.2 [9.5] | 125.4 [28.5] | 66.0 [15] | 31.2 [7.1] | 113.1 [25.7] |
| MAGNA3 50-80 F (N) | 14.8 [4.5] | 129.8 [29.5] | 74.8 [17] | 32.6 [7.4] | 117.0 [26.6] |
| MAGNA3 50-150 F (N) | 26.2 [8.0] | 165.0 [37.5] | 88.0 [20] | 41.4 [9.4] | 148.7 [33.8] |
| MAGNA3 65-120 F (N) | 21.3 [6.5] | 209.0 [47.5] | 132.0 [30] | 52.4 [11.9] | 188.3 [42.8] |
| MAGNA3 (D) 65-150 F (N)* | 26.2 [8.0] | 248.6 [56.5] | 176.0 [40] | 62.0 [14.1] | 224.0 [50.9] |
| MAGNA3 (D) 80-100 F (N)* | 18.0 [5.5] | 297.0 [67.5] | 206.8 [47] | 74.4 [16.9] | 267.5 [60.8] |
| MAGNA3 (D) 100-120 F (N)* | 21.3 [6.5] | 345.4 [78.5] | 250.8 [57] | 86.2 [19.6] | 311.1 [70.7] |

The operating range for proportional-pressure and constant-pressure control appears from the individual data sheet.
Constant-curve duty: 0 to 100 % speed.

* Stainless steel version available for single head unit only.

Additional operating modes for multi-pump setup

Multi-pump function

The multi-pump function enables the control of single-head pumps connected in parallel and twin-head pumps without the use of external controllers. The pumps in a multi-pump system communicate with each other via the wireless GENlair connection.

A multi-pump system is set up via a selected pump, i.e. the master pump (first selected pump). The multi-pump functions are described in the following sections.

Alternating operation

Only one pump is operating at a time. The change from one pump to the other depends on time or energy. If a pump fails, the other pump will take over automatically.

Pump system:

- Twin-head pump.
- Two single-head pumps connected in parallel. The pumps must be of equal size and type. Each pump requires a non-return valve in series with the pump.

Back-up operation

One pump is operating continuously. The back-up pump is operated at intervals to prevent seizing up. If the duty pump stops due to a fault, the back-up pump will start automatically.

Pump system:

- Twin-head pump.
- Two single-head pumps connected in parallel. The pumps must be of equal size and type. Each pump requires a non-return valve in series with the pump.

Cascade operation

Cascade operation ensures that the pump performance is automatically adapted to the consumption by switching pumps on or off. The system thus runs as energy-efficiently as possible with a constant pressure and a limited number of pumps.

The back-up of a twin-head pump will start at 90 % and stop at 50 % performance when operating in constant-pressure mode.

It can be advantageous to choose a twin-head pump, as the back-up pump will start for a short period in peak-load situations. If an oversized single-head pump is chosen, it may run outside its best efficiency range most of the time.

All pumps in operation will run at equal speed. Pump changeover is automatic and depends on speed, operating hours and fault.

Pump system:

- Twin-head pump.
- Two single-head pumps connected in parallel. The pumps must be of equal size and type. Each pump requires a non-return valve in series with the pump.
- The control mode must be set to "Const. press." or "Constant curve".

Readings and settings on the pump

Control panel and display

The MAGNA3 pump features a 4" TFT display with intuitive and user-friendly interface. The control panel has self-explanatory push-buttons made of high-quality silicone for precise navigation in the menu structure. The control panel is designed to give the user quick and easy access to pump and performance data on site.

When the pump is started up for the first time, the user is presented with a start-up guide enabling easy setting of the pump. Additionally, the "Assist" menu can guide the user through the various settings of the pump.



TM05 7642 2113

Fig. 23 Control panel

| Button | Function |
|--------|--------------------------------------------------------------------------------------------------------------------------------------------|
| | Goes to the "Home" menu. |
| | Returns to the previous action. |
| | Navigates between main menus, displays and digits. When the menu is changed, the display will always show the top display of the new menu. |
| | Navigates between submenus. |
| | Saves changed values, resets alarms and expands the value field. |

Factory setting

The pumps have been factory-set to AUTO_{ADAPT} without Automatic Night Setback.

Start-up guide

The start-up guide is used for the general settings of the pump. The start-up guide is started the first time the pump is connected to the power supply.

Note: If there has been no user action after pump start-up, the pump will automatically leave the start-up guide after 15 minutes with the language set to English.

The start-up guide can be run again in the "Settings" menu. If the start-up guide is run again, all previous settings will be lost.

"Home" menu

This menu gives an overview of up to four user-defined parameters or a graphical illustration of a Q/H performance curve.

This menu offers the following (factory setting):

- Shortcut to Control mode settings
- Shortcut to Setpoint settings
- Flow rate
- Head.



Fig. 24 "Home" menu

"Status" menu

This menu shows the status of the pump and system as well as warnings and alarms.

Note: No settings can be made in this menu.

This menu offers the following:

- Operating status
- Pump performance
- Power and energy consumption
- Warning and alarm
- Heat energy meter
- Work log
- Fitted modules
- Date and time
- Pump identification
- Multi-pump system.

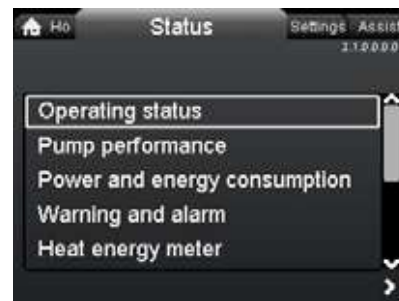

Fig. 25 "Status" menu

"Settings" menu

This menu gives access to all setting parameters. A detailed setting of the pump can be made in this menu.

This menu offers the following setting options:

- Setpoint
- Operating mode
- Control mode
- FLOW_{LIMIT}
- Automatic Night Setback
- Relay outputs
- Setpoint influence
- Bus communication
- General settings.



Fig. 26 "Settings" menu

TM057641 1313

Status

Settings

"Assist" menu

The "Assist" menu guides the user through the setting of the pump. In each submenu, the user is presented with a guide that assists throughout the setting.

This menu offers the following:

- Step-by-step instructions in how to set up the pump.
- A short description of the six control modes and recommended applications.
- Assistance in fault correction.

Submenus:

- Assisted pump setup
- Setting of date and time
- Multi-pump setup
- Setup, analog input
- Description of control mode
- Assisted fault advice.

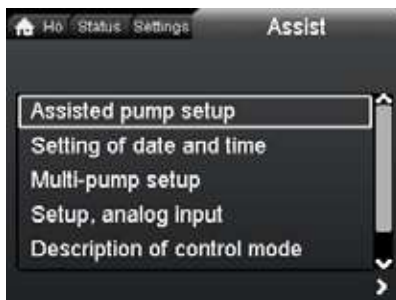

Fig. 27 "Assist" menu

Operating status

"Operating status" shows the current operating mode and the selected control mode, if any.

Pump performance

"Pump performance" offers the following:

- Q/H graph showing current duty point, flow, head, power and liquid temperature.
- "Resulting setpoint" shows the setpoint set on the pump, the external influence and the resulting setpoint.
- Liquid temperature.
- Speed.
- Operating hours.

Warning and alarm

"Warning and alarm" offers the following:

- Actual warning or alarm, if any.
- Information about when the warning/alarm occurred and disappeared and about corrective actions.
- Warning and alarm logs.

Heat energy meter

"Heat energy meter" is a monitoring function which makes it possible to track the heat energy distribution and consumption within a system. This prevents excessive energy costs caused by system imbalances.

- The heat energy meter has an accuracy between ± 1 and 10 %, i.e. ideal for optimization purposes.
- Temperature input from the return pipe. The temperature sensor is not supplied with the pump.

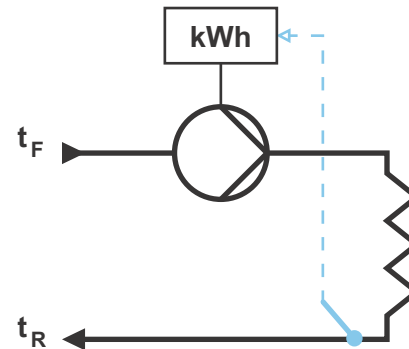

Fig. 28 MAGNA3 with built-in heat energy meter

Note: MAGNA3 incorporates a calculator for flow and flow-pipe temperature.

For further details, see section [Curve conditions](#), page 32.

Work log history

"Work log history" offers the following:

- Every duty point and the operating conditions are tracked and stored in the pump.
- The 3D work log and duty curve (over time) provide instant overviews of historical pump performance and operating conditions.
- The perfect tool for pump optimization, replacement and fault finding.

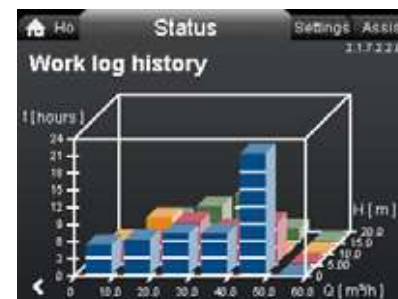

Fig. 29 Example of "Work log history"

Input for external sensor

An external differential-pressure sensor can be used to control the flow in the system to obtain the externally set pressure, which results in following benefits:

- Minimizes operating costs.
- Prevents valve noise.
- Ensures comfort (enough pressure).

Grundfos Eye

The Grundfos Eye at the top of the control panel is a pump status indicator light providing information about the pump operating status.

The indicator light will flash in different sequences and provide information about the following:

- power on/off
- pump warnings
- pump alarms
- remote control.

The function of the Grundfos Eye is described in detail in the installation and operating instructions.



<http://GRUNDFOS.COM/MAGNA3-MANUAL>



Fig. 30 Grundfos Eye

TM05 3810 1612

Communication

The MAGNA3 enables communication via the following:

- wireless Grundfos GO Remote
- fieldbus communication via CIM modules
- digital inputs
- relay outputs
- analog input.

Grundfos GO Remote



TM05 3825 1712

Fig. 31 Grundfos GO Remote

The MAGNA3 is designed for wireless communication with the Grundfos GO Remote.

For more details, see section [Grundfos GO Remote](#), page 31.

The Grundfos GO Remote offers additional possibilities of setting and status displays for the pump.

The Grundfos GO Remote can be used for the following functions:

- Reading of operating data.
- Reading of warning and alarm indications.
- Setting of control mode.
- Setting of setpoint.
- Selection of external setpoint signal.
- Allocation of pump number making it possible to distinguish between pumps that are connected via Grundfos GENibus.
- Selection of function for digital input.
- Generation of reports (PDF).
- Assist function.
- Multi-pump setup.
- Displaying relevant documentation.

Wireless GENIair

The pump is designed for multi-pump connection via the wireless GENIair connection.

The built-in wireless GENIair module enables communication between pumps and with the Grundfos GO Remote without the use of add-on modules.

- Multi-pump function.
See section [Multi-pump function](#).
- Grundfos GO Remote.
See section [Grundfos GO Remote](#).

CIM modules



TM05 3811 1612

Fig. 32 Grundfos CIM modules

A CIM module is an add-on Communication Interface Module. The CIM module enables data transmission between the pump and an external system, for example a BMS (Building Management System) or SCADA system.





The CIM module communicates via fieldbus protocols. Available CIM modules can be found on page [21](#).

Connection to network

The pump can be connected to a LON network via the wireless GENIair connection or by fitting a CIM module. See section [CIM modules](#), page [30](#).

Other types of network connections are also possible. Contact Grundfos for further information on how to connect to your network.

Available CIM modules

| Module | Fieldbus protocol | Description | Functions |
|-------------------------------------------------------------------------------------------------------|--------------------------------|--------------------------------------------------------------------------------------------------------------|-------------------------------------------------------------------------------------------------------------------------------------------------------------------------------------------------------------------------------------------------------------------------------------------------------------------------------------------------------------------------------------------------------------------------------------------------------------------------------------|
| CIM 050  | GENIbus TM05 3812 1612 | The CIM 050 is a Grundfos communication interface module used for communication with a GENIbus network. | The CIM 050 has terminals for the GENIbus connection. |
| CIM 100  | LonWorks TM05 3813 1612 | The CIM 100 is a Grundfos communication interface module used for communication with a LonWorks network. | The CIM 100 has terminals for the LonWorks connection. Two LEDs are used to indicate the actual status of the CIM 100 communication. One LED is used for indication of correct connection to the pump, and the other is used to indicate LonWorks communication status. |
| CIM 150  | Profibus DP TM05 3814 1612 | The CIM 150 is a Grundfos communication interface module used for communication with a Profibus network. | The CIM 150 has terminals for the Profibus DP connection. DIP switches are used to set line termination. Two hexadecimal rotary switches are used to set the Profibus DP address. Two LEDs are used to indicate the actual status of the CIM 150 communication. One LED is used for indication of correct connection to the pump, and the other is used to indicate Profibus communication status. |
| CIM 200  | Modbus RTU TM05 3815 1612 | The CIM 200 is a Grundfos communication interface module used for communication with a Modbus RTU network. | The CIM 200 has terminals for the Modbus connection. DIP switches are used to select parity and stop bits, to select transmission speed and to set line termination. Two hexadecimal rotary switches are used to set the Modbus address. Two LEDs are used to indicate the actual status of the CIM 200 communication. One LED is used for indication of correct connection to the pump, and the other is used to indicate Modbus communication status. |
| CIM 300  | BACnet MS/TP TM05 3815 1612 | The CIM 300 is a Grundfos communication interface module used for communication with a BACnet MS/TP network. | The CIM 300 has terminals for the BACnet MS/TP connection. DIP switches are used to set transmission speed and line termination and to select the custom Device Object Instance Number. Two hexadecimal rotary switches are used to set the BACnet address. Two LEDs are used to indicate the actual status of the CIM 300 communication. One LED is used for indication of correct connection to the pump, and the other is used to indicate BACnet communication status. |

For product numbers, see section [CIM modules](#), page 30.

4. Operating conditions

General recommendations

| | |
|---------------------------------|--------------------------------------------------------------------------------|
| Water in heating systems | Water quality according to local standards |
| Domestic hot water | Degree of hardness up to 14 °dH |
| Water containing glycol | Maximum viscosity = 50 cSt ~ 50 % water/50 % ethylene glycol at 14 °F [-10 °C] |

Liquid temperature

| Application | Temperature range |
|----------------------------|-----------------------------------|
| General | 14 to 230 °F [-10 to +110 °C] |
| Domestic hot-water systems | 150 °F [Up to +65 °C] recommended |

Ambient conditions

| Ambient conditions | |
|--------------------------------------------------|-------------------------------|
| Ambient temperature during operation | 32 - 140 °F [0 to +40 °C] |
| Ambient temperature during storage and transport | -40 to 158 °F [-40 to +70 °C] |
| Relative air humidity | Maximum 95 % |

Maximum operating pressure

175 psi [12 bar]

Minimum inlet pressure

The following relative minimum pressure must be available at the pump inlet during operation to avoid cavitation noise and damage to the pump bearings.

The values in the table below apply to single-head pumps and twin-head pumps in single-head operation.

| MAGNA3 DN | Liquid temperature | | |
|--------------------------|--------------------|-------------------|--------------------|
| | 167 °F [75 °C] | 203 °F [95 °C] | 230 °F [110 °C] |
| Inlet pressure psi [bar] | | | |
| 40-80 | 1.5 [0.10] | 7.3 [0.50] | 16.0 [1.1] |
| 40-120/150/180 | 1.5 [0.10] | 5.8 [0.40] | 14.5 [1.0] |
| 50-80 | 1.5 [0.10] | 1.5 [0.10] | 10.2 [0.7] |
| 50-150 | 2.9 [0.20] | 8.7 [0.60] | 17.4 [1.2] |
| 65-120 | 1.5 [0.10] | 7.3 [0.50] | 16.0 [1.1] |
| 65-150 | 5.8 [0.40] | 11.6 [0.80] | 17.4 [1.2] |
| 80-100 | 7.3 [0.50] | 13.1 [0.90] | 21.8 [1.5] |
| 100-120 | 7.3 [0.50] | 13.1 [0.90] | 21.8 [1.5] |

In the case of twin-head operation, the required relative inlet pressure must be increased by 1.45 psi [0.1 bar] compared to the stated values for single-head pumps or twin-head pumps in single-head operation.

Note: Actual inlet pressure plus pump pressure against a closed valve must be lower than the maximum permissible system pressure.

The relative minimum inlet pressures apply to pumps installed up to 984 ft [300 m] above sea level. For altitudes above 984 ft [300 m], the required relative inlet pressure must be increased by 1.45 psi per 330 ft [0.1 bar / 0.01 MPa per 100 m] altitude. The MAGNA3 pump is only approved for an altitude of 6560 ft [2000 m].

Pumped liquids

The pump is suitable for thin, clean, non-aggressive and non-explosive liquids, not containing solid particles or fibres that may attack the pump mechanically or chemically.

In heating systems, the water should meet the requirements of accepted standards on water quality in heating systems.

In domestic hot-water systems, we recommend to use MAGNA3 pumps only for water with a degree of hardness lower than approx. 14 °dH.

In domestic hot-water systems, we recommend to keep the liquid temperature below 149 °F [+65 °C] to eliminate the risk of lime precipitation.

The MAGNA3 pumps can be used for pumping water/glycol mixtures up to 50 %.

Example of a water/ethylene glycol mixture:

Maximum viscosity: 50 cSt ~ 50 % water/50 % ethylene glycol mixture at 14 °F [-10 °C].

The pump is controlled by a power-limiting function that protects against overload.

The pumping of glycol mixtures will affect the max. curve and reduce the performance, depending on the water/ethylene glycol mixture and the liquid temperature.

To prevent the ethylene glycol mixture from degrading, avoid temperatures exceeding the rated liquid temperature and minimise the operating time at high temperatures.

It is important to clean and flush the system before the ethylene glycol mixture is added.

To prevent corrosion or lime precipitation, check and maintain the ethylene glycol mixture regularly. If further dilution of the supplied ethylene glycol is required, follow the glycol supplier's instructions.

Differential-pressure and temperature sensor

The MAGNA3 incorporates a differential-pressure and temperature sensor. The sensor is located in the pump housing in a channel between the suction and discharge ports. The sensors of twin-head pumps are connected to the same channel and the pumps therefore register the same differential pressure and temperature.

Via a cable, the sensor sends an electrical signal for the differential pressure across the pump and for the liquid temperature to the controller in the control box.

In case of missing sensor signal, the pump will run at maximum speed. When the fault has been corrected, the pump will continue operating according to the parameters set.

The differential-pressure and temperature sensor offers substantial benefits:

- direct feedback on the pump display
- complete pump control
- measurement of the pump workload for precise and optimum control resulting in higher energy efficiency.

Electrical data

| | |
|---------------------------------------------|---------------------------------------------------------------------------------------------------------------------------------------------------------------------------------------------------------------------------------------------------------------|
| Pump type | MAGNA3 (D) |
| Enclosure class | Type 2 |
| Insulation class | F. |
| Supply voltage | 1 x 115/208-230 V ± 10 %, 50/60 Hz, PE. |
| Two digital inputs | External potential-free contact. Contact load: 5 V, 10 mA. Screened cable. Loop resistance: Maximum 130 Ω. |
| Analog input | 4-20 mA (load: 150 Ω). 0-10 VDC (load: > 10 kΩ). |
| Two relay outputs | Internal potential-free changeover contact. Maximum load: 250 V, 2 A, AC1. Minimum load: 5 VDC, 20 mA. Screened cable, depending on signal level. |
| Bus input | Grundfos Communication Interface Modules (add-on CIM modules) for <ul style="list-style-type: none"> • GENibus • LonWorks • Profibus DP • Modbus RTU • BACnet MS/TP • Grundfos Remote Management. |
| Earth leakage current | $I_{leakage} < 3.5 \text{ mA}$. The leakage currents are measured in accordance with EN 60335-1. |
| EMC | EN 55014-1:2006, EN 55014-2:1998, EN 61800-3-3:2008 and EN 61000-3-2:2006. |
| cos φ | The MAGNA3 has a built-in active PFC (Power Factor Control) which gives a cos φ from 0.98 to 0.99, i.e. very close to 1. |
| Consumption when the pump is stopped | 1 to 10 W, depending on activity, i.e. reading the display, use of Grundfos GO Remote, interaction with modules, etc. 4 W, when pump is stopped and no activity. |

Sound pressure level

| | |
|-----------------------------|---------------|
| Pump type | MAGNA3 |
| Sound pressure level | ≤ 43 dB(A) |

5. Construction

The MAGNA3 is of the canned-rotor type, i.e. pump and motor form an integral unit without shaft seal and with only two gaskets for sealing. The bearings are lubricated by the pumped liquid.

The pump is characterized by the following:

- controller integrated in the control box
- control panel on the control box
- control box prepared for optional CIM modules
- built-in differential-pressure and temperature sensor
- cast-iron or stainless-steel pump housing
- twin-head versions
- no external motor protection required
- insulating shells supplied with single-head pumps for heating systems.

Motor and electronic controller

The MAGNA3 incorporates a 4-pole synchronous, permanent-magnet motor (PM motor). This motor type is characterised by higher efficiency than a conventional asynchronous squirrel-cage motor. The pump speed is controlled by an integrated frequency converter.

A differential-pressure and temperature sensor is incorporated in the pump.

Pump connections

See individual product pages.

Surface treatment

The pump housing and pump head are electrocoated to improve the corrosion resistance.

Electrocoating includes:

- alkaline cleaning
- pretreatment with zinc phosphate coating
- cathodic electrocoating (epoxy)
- curing of paint film at 392 to 482 °F [200 to 250 °C].

Color

Color codes for the pump:

| color | Code |
|-------|-----------|
| Red | NCS40-50R |
| Black | NCS9000 |

Sectional drawing

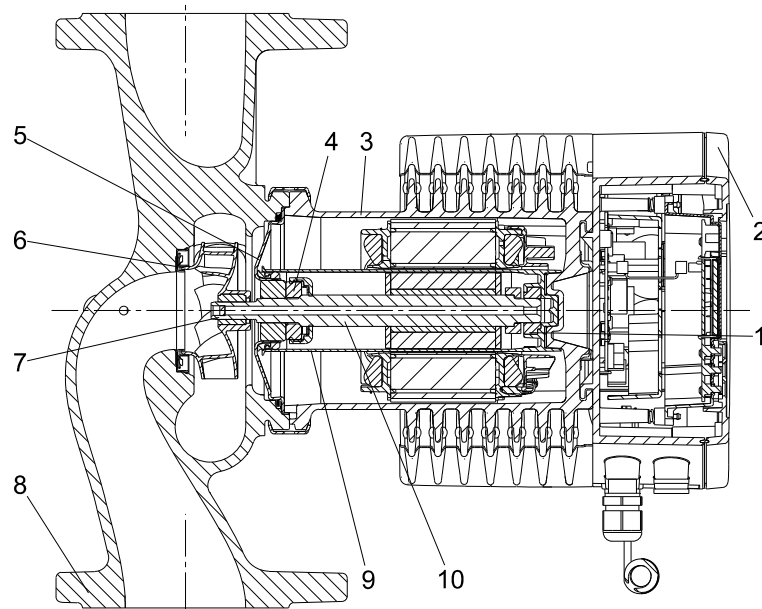

TM05 2319 0312

Fig. 33 MAGNA3

Material specification

| Pos. | Component | Material |
|------|--------------------|---------------------------------|
| 1 | Outer bearing ring | Aluminium oxide |
| 2 | Control box | Polycarbonate |
| 3 | Stator housing | Aluminium |
| | O-rings | EPDM |
| 4 | Thrust bearing | Aluminium oxide/carbon |
| 5 | Bearing plate | Stainless steel (304) |
| 6 | Neck ring | Stainless steel (304) |
| 7 | Impeller | PES |
| 8 | Pump housing | Cast iron/stainless steel (316) |
| 9 | Rotor can | PPS |
| 10 | Shaft | Stainless steel (316L) |

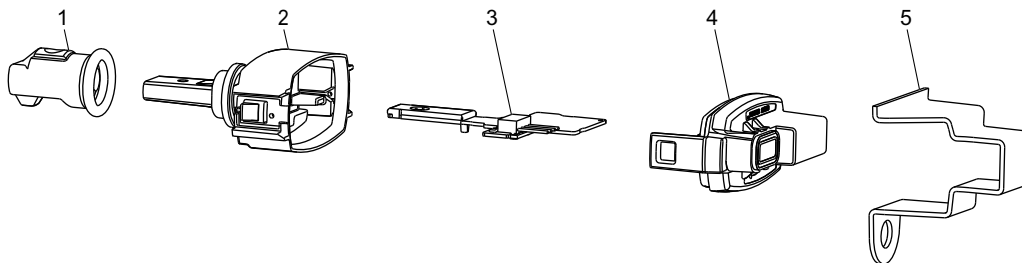

TM05 3035 0812

Fig. 34 Sensor

| Pos. | Component | Material |
|------|-----------------------|-----------------|
| 1 | Sealing cap | EPDM |
| 2 | Housing | PPS |
| 3 | Printed-circuit board | - |
| 4 | Cover snap-on | PA/TPV |
| 5 | Bracket for sensor | Stainless steel |

6. Installation

Mechanical installation

The MAGNA3 is designed for indoor installation.

The pump must be installed with horizontal motor shaft.

The pump may be installed in horizontal as well as vertical pipes.



Fig. 35 Installation positions

Arrows on the pump housing indicate the liquid flow direction through the pump.

The control box must be in horizontal position with the Grundfos logo in vertical position. See fig. 35.

This is described in the installation and operating instructions.



<http://GRUNDFOS.COM/MAGNA3-MANUAL>

The pump must be installed in such a way that it is not stressed by the pipework.

The pump may be suspended direct in the pipes, provided that the pipework can support the pump.

Twin-head pumps are prepared for installation on a mounting bracket or base plate.

To ensure adequate cooling of motor and electronics, the following must be observed:

- Position the pump in such a way that sufficient cooling is ensured.
- The temperature of the ambient air must not exceed 104 °F [+40 °C].

Insulating shells

The insulating shells supplied with single-head MAGNA3 pumps are for heating systems and should be fitted as part of the installation.

Insulating shells for air-conditioning and cooling systems are available as an accessory.

See section *Insulating for air-conditioning and cooling systems*, page 30.

Note: Insulating shells are not available for twin-head pumps.

Electrical installation

The electrical connection and protection should be carried out in accordance with local regulations.

- The pump must be connected to an external mains switch.
- The pump must always be correctly earthed.
- The pump requires no external motor protection.
- The pump incorporates thermal protection against slow overloading and blocking.
- When switched on via the power supply, the pump will start pumping after approx. 5 seconds.

Note: The number of starts and stops via the power supply must not exceed four times per hour.

The pump has a digital input that can be used for external control of start/stop without switching the power supply on/off.

The pump mains connection must be made as shown in the diagrams on the following pages.

Cables

Use screened cables for external on/off switch, digital input, sensor and setpoint signals.

- All cables used must be heat-resistant up to at least 185 °F [+85 °C].
- All cables used must be installed in accordance with EN 60204-1 and EN 50174-2:2000.

Additional protection

If the pump is connected to an electric installation where an earth leakage circuit breaker (ELCB) is used as an additional protection, this circuit breaker must trip when earth fault currents with DC content (pulsating DC) occur.

The earth leakage circuit breaker must be marked with the first or both of the symbols shown below:

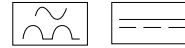

| Symbol | Description |
|--------|-------------------------------------------------------|
| | High-sensitivity ELCB, type A, according to IEC 60775 |
| | High-sensitivity ELCB, type B, according to IEC 60775 |

Examples of connections

Supply connection

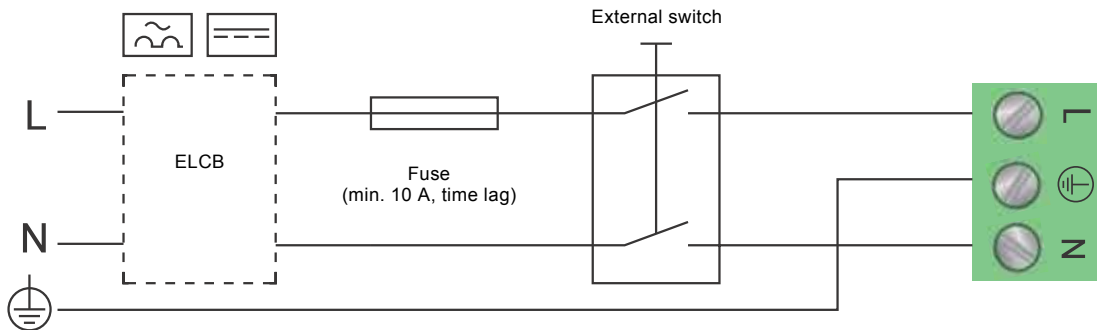

Fig. 36 Example of typical connection, 1 x 230 V ± 10 %, 50/60 Hz

As a minimum, a 10 A time-lag fuse must be installed due to the start-up power of the MAGNA3.

Connection to external controllers

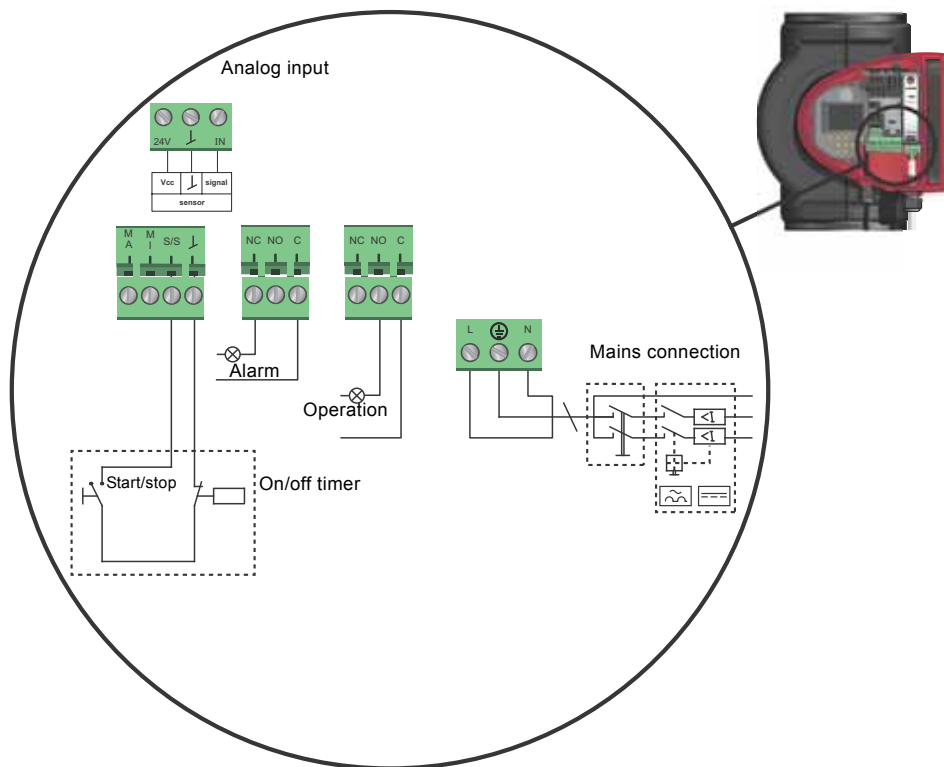

Fig. 37 Example of connections in the control box

TM03 2397 0312

TM05 2673 3812

Digital inputs

The digital input can be used for external control of start/stop or forced max. or min. curve.

Note: If no external on/off switch is connected, the jumper between terminals Start/Stop (S/S) and frame (\downarrow) should be maintained. This connection is the factory setting.

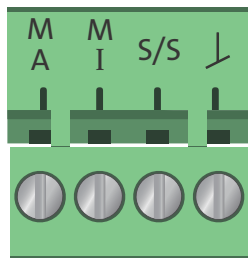

Fig. 38 Digital input in control box

| Contact symbol | Function |
|----------------|------------------|
| M A | Max. curve |
| M I | Min. curve |
| S/S | Start/Stop |
| \downarrow | Frame connection |

External start/stop

The pump can be started or stopped via the digital input.

| Start/stop | | |
|------------|--|-------------|
| | | Normal duty |
| | | Stop |

External forced max. or min curve

The pump can be forced to operate on the max. or min. curve via the digital input.

| Max. curve | | |
|------------|--|-------------|
| | | Normal duty |
| | | Max. curve |

TM05 3343 1212

| Min. curve | | |
|------------|--|-------------|
| | | Normal duty |
| | | Min. curve |

Relay outputs

The pump has two signal relays with a potential-free changeover contact for external fault indication.

The function of the signal relay can be set to "Alarm", "Ready" or "Operation" on the pump control panel or with the Grundfos GO Remote.

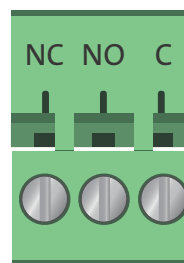

Fig. 39 Relay output in control box

| Contact symbol | Function |
|----------------|-----------------|
| NC | Normally closed |
| NO | Normally open |
| C | Common |

The functions of the signal relays are as shown in the table below:

Signal relay Alarm signal



- Not activated:
- The power supply has been switched off.
 - The pump has not registered a fault.



- Activated:
- The pump has registered a fault.

Signal relay Ready signal



- Not activated:
- The pump has registered a fault and is unable to run.



- Activated:
- The pump has been set to stop, but is ready to run.
 - The pump is running.

Signal relay Operating signal



- Not activated:
- The pump is not running.



- Activated:
- The pump is running.

TM05 3343 1212

Analog input for external sensor

The analog input can be used for the connection of an external sensor for measuring temperature, pressure, flow or other parameter.

The analog input can also be used for an external signal for the control from a BMS system or similar control system.

The electrical signal for the input can be 0-10 VDC or 4-20 mA.

The selection of electrical signal (0-10 V or 4-20 mA) can be changed on the control panel or with the Grundfos GO Remote.

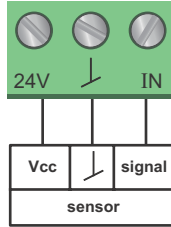

Fig. 40 Analog input for external sensor or control

TM05 3221 1112

In order to optimize the pump performance, external sensors can advantageously be used in the following cases:

| Function/control mode | Sensor type |
|-----------------------|--------------------|
| Heat energy meter | Temperature sensor |
| Constant temperature | Temperature sensor |
| Proportional pressure | Pressure sensor |

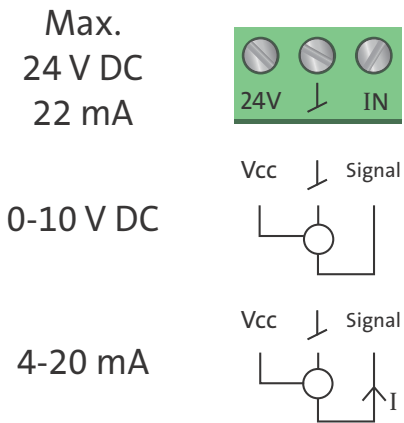

Fig. 41 Wiring, analog input

TM05 3343 1212

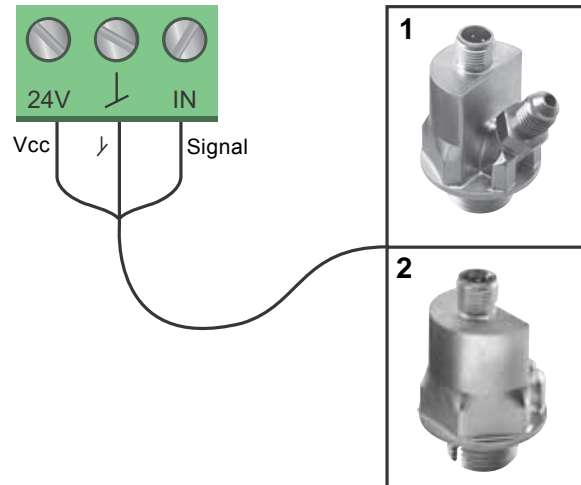

Fig. 42 Examples of external sensors

TM05 2947 1212

| Pos. | Sensor type |
|------|-------------------------------------------------------------------------------------|
| 1 | Temperature transmitter, Danfoss type MBT 3560, 1/2" connection and 4-20 mA signal. |
| 2 | Pressure transmitter, Grundfos type RPI. 1/2" connection and 4-20 mA signal. |

For further details, see section [Curve conditions](#), page 32.

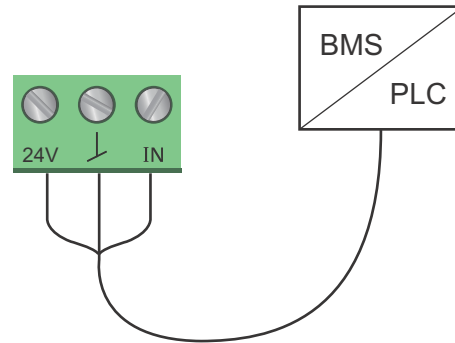

Fig. 43 Example of external signal for the control via BMS or PLC

TM05 2888 0612

7. Accessories

Insulating for air-conditioning and cooling systems

For cooling applications, if the supplied insulation shell is to be used then a silicon sealant must be liberally applied to the inside of the insulation shell to ensure all air gaps are eliminated between the shell and pump housing to prevent condensation inside the shell.



TM05 2874 0412

Fig. 44 Fitting the insulating shells to a MAGNA3 pump

CIM modules

A CIM module is an add-on Communication Interface Module. The CIM module enables data transmission between the pump and an external system, for example a BMS or SCADA system.

The CIM module communicates via fieldbus protocols. The following CIM modules are available:

| Module | Fieldbus protocol | Product number |
|---------|-------------------|----------------|
| CIM 050 | GENIbus | 96824631 |
| CIM 100 | LonWorks | 96824797 |
| CIM 150 | Profibus DP | 96824793 |
| CIM 200 | Modbus RTU | 96824796 |
| CIM 300 | BACnet MS/TP | 96893770 |

For further information about data communication via CIM modules, see the CIM documentation available in WebCAPS.

Location of CIM module

The CIM module is fitted behind the front cover. See fig. 45.

For installation, see separate installation and operating instructions.



<http://GRUNDFOS.COM/MAGNA3-MANUAL>

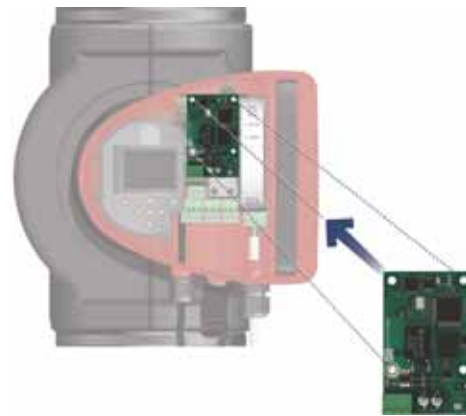

TM05 2914 1112

Fig. 45 Location of CIM module

Grundfos GO Remote

The pump is designed for wireless communication with the Grundfos GO Remote app which communicates with the pump via radio communication.

Note: The radio communication between the pump and the Grundfos GO Remote is encrypted to protect against misuse.

The Grundfos GO Remote app is available from Apple App Store and Android market.

The Grundfos GO Remote app must be used in conjunction with one of the following Mobile Interface devices:

| Mobile interface | Product number |
|------------------|----------------|
| Grundfos MI 201 | 98140638 |
| Grundfos MI 202 | 98046376 |
| Grundfos MI 301 | 98046408 |

The Grundfos GO Remote concept replaces the Grundfos R100 remote control. This means that all products supported by the R100 are supported by the Grundfos GO Remote.

For function and connection to the pump, see separate installation and operating instructions for the desired type of Grundfos GO Remote setup.

Mobile interface

The three mobile interface devices are described in the following.

MI 201

The MI 201 is a complete solution, consisting of an Apple iPod touch 4G and a Grundfos cover for infrared and radio communication with Grundfos pumps or systems.



Fig. 46 MI 201

Supplied with the product:

- Apple iPod touch 4G incl. accessories
- Grundfos MI 201 cover
- battery charger
- quick guide.

TM05 3886 1612

MI 202

The MI 202 is an add-on module with built-in infrared and radio communication. The MI 202 can be used in conjunction with Apple iPod touch 4G, iPhone 4G or later.



TM05 3887 1612

Fig. 47 MI 202

Supplied with the product:

- Grundfos MI 202
- quick guide.

MI 301

The MI 301 is a module with built-in infrared and radio communication. The MI 301 must be used in conjunction with an Android or iOS-based Smartphone with a Bluetooth connection. The MI 301 has a rechargeable Li-ion battery that must be charged separately.



TM05 3887 1612

Fig. 48 MI 301

Supplied with the product:

- Grundfos MI 301
- battery charger
- quick guide.

Supported units

| Make | Model | Operating system | MI 201 | MI 202 | MI 301 |
|---------|----------------|------------------------|--------|--------|--------|
| Apple | iPod touch 4G | iOS 5.0 or later | • | • | • |
| | iPhone 4G, 4GS | | - | • | • |
| HTC | Desire S | Android 2.3.3 or later | - | - | • |
| | Sensation | Android 2.3.4 or later | - | - | • |
| Samsung | Galaxy S II | Android 2.3.4 or later | - | - | • |

Note: Similar Android and iOS-based devices may work as well, but are not supported by Grundfos.

8. Curve conditions

Performance curves

The guidelines below apply to the performance curves on pages X to X:

- Test liquid: airless water.
- The curves apply to a density of $\rho = 61.38 \text{ lb/ft}^3$ [983.2 kg/m^3] and a liquid temperature of $140 \text{ }^\circ\text{F}$ [$+60 \text{ }^\circ\text{C}$].
- All curves show average values and should not be used as guarantee curves. If a specific minimum performance is required, individual measurements must be made.
- The curves apply to a kinematic viscosity of $\nu = 0.474 \text{ mm}^2/\text{s}$ (0.474 cSt).
- Reference supply voltage: $1 \times 230 \text{ V}$, 50 Hz .
- EEI obtained according to EN 16297.

Note: Within the MAGNA3 performance range, the constant- and proportional-pressure curves can be set in steps of 0.1 m head on the control panel or with the Grundfos GO Remote.

Symbols used on the following pages



Fig. 49 Energy efficiency index (EEI)

The MAGNA3 is energy-optimized and complies with the EuP Directive (Commission Regulation (EC) No 641/2009) which will be effective as from 1 January 2013.

For MAGNA3 pumps, the average energy efficiency index (EEI) is 0.18 with values down to 0.17 , categorised as best in class.

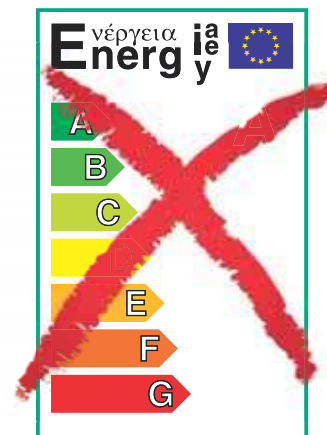

Fig. 50 Old energy label

From 1 January 2013, the old A to G energy label will be replaced by the new energy efficiency index (EEI). Only the best of today's A-labelled circulator pumps will meet the new requirements.

The MAGNA3 with its $\text{AUTO}_{\text{ADAPT}}$ function is the preferred choice for large heating systems and a true efficiency frontrunner.

Figure 51 shows the energy consumption index for a typical circulator pump compared to the various EEI limits.

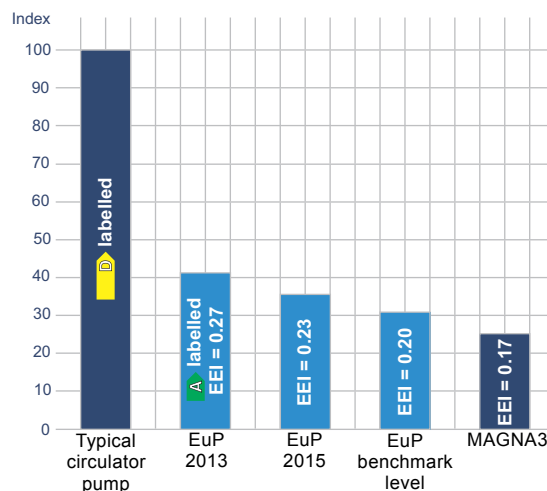

Fig. 51 Energy consumption index

With an energy efficiency index (EEI) well below the EuP benchmark level. With $\text{AUTO}_{\text{ADAPT}}$ the savings can be as much as 85% , compared to a typical circulator pump and thus a remarkably fast return on investment. This means, of course, that the MAGNA3 more than meets the standards of the EuP legislation.

For more information about the new energy directive, please visit:



<http://energy.Grundfos.com>



Fig. 52 Grundfos blueflux®

The Grundfos blueflux® label is your guarantee that the MAGNA3 incorporates the most energy-efficient motor currently available. Grundfos blueflux® motors are designed to cut the power consumption by up to 60 % and thus reduce CO₂ emissions and operating costs.

TM05 2683 0412

TM05 2683 0412

QR code on pump nameplate



TM05 3826 1712

Fig. 53 QR code on pump nameplate

With the Grundfos GO Remote or a smartphone, it is possible to get the following information about the MAGNA3:

- product photo
- pump performance curves
- dimensional sketches
- wiring diagram
- quotation text
- technical data
- service parts list
- PDF files, such as data booklet and installation and operating instructions.

9. Performance curves

MAGNA3 40-80 F (N)

1 x 115 & 208-230 V, 50/60 Hz

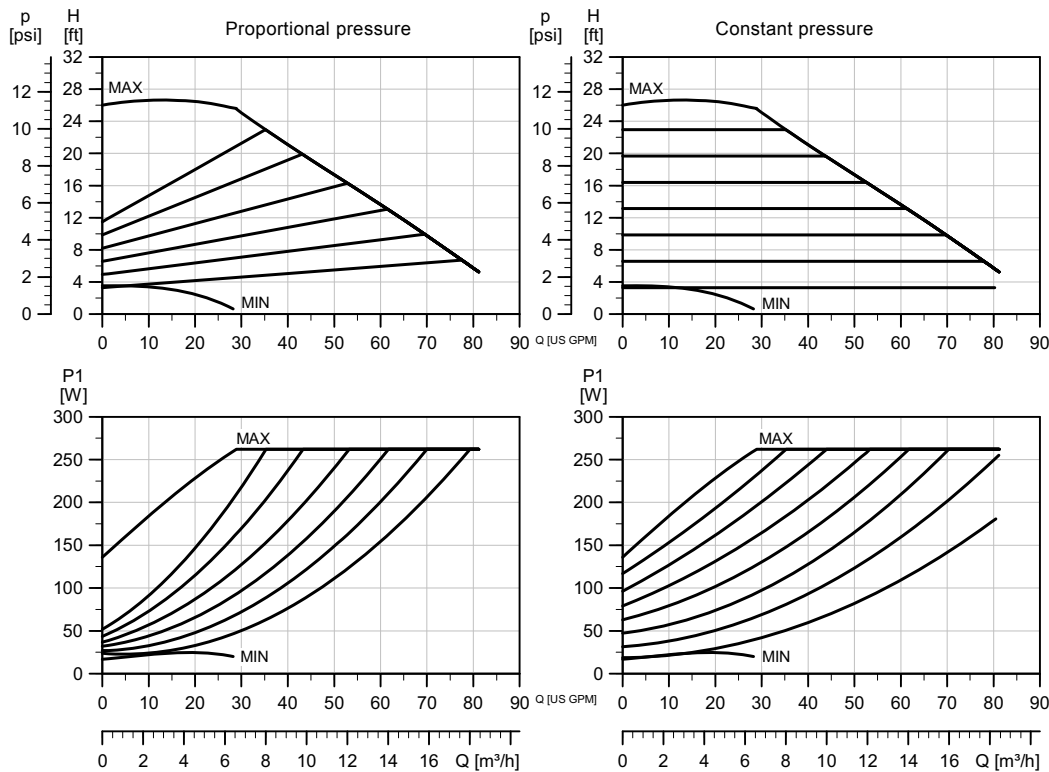

| Speed | I _{1/1} [A] 115 V | P1 [W] 115 V | I _{1/1} [A] 230 V | P1 [W] 230 V |
|-------|----------------------------|--------------|----------------------------|--------------|
| Min. | 0.3 | 16 | 0.19 | 16 |
| Max. | 2.45 | 276 | 1.20 | 265 |

The pump incorporates overload protection.

System pressure: Max. 175 psi [12 bar].
 Liquid temperature: 14 to 230 °F [-10 °C to +110 °C].
 Also available with: Stainless-steel pump housing, type N.
 Specific EEI: 0.19.

| Net weights lbs [kg] | Gross weights lbs [kg] | Ship. vol.ft ³ [m ³] |
|----------------------|------------------------|---------------------------------------------|
| 35 [15.9] | 41 [18.7] | 1.41 [0.04] |

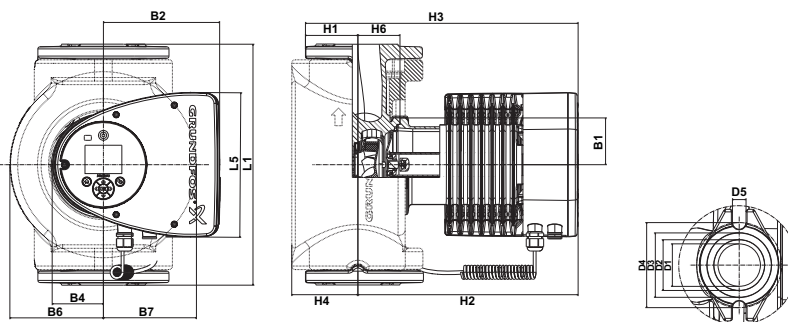

| Pump type | Dimensions in. [mm] | | | | | | | | |
|--------------------|---------------------|------------|------------|------------|-------------|------------|------------|-----------|-----------|
| | L1 | L5 | B1 | B2 | B4 | B6 | B7 | D1 | D2 |
| MAGNA3 40-80 F (N) | 8.5 [216] | 8.03 [204] | 3.31 [84] | 6.46 [164] | 2.87 [73] | 4.37 [111] | 4.37 [111] | 1.57 [40] | 1.93 [49] |
| | D3 | D4 | D5 | H1 | H2 | H3 | H4 | H6 | |
| | 2.4 [60] | 3.15 [80] | 0.5 [12.8] | - | 11.97 [304] | - | 2.76 [70] | 1.97 [50] | |

TM05 7651 1413

MAGNA3 40-120 F (N)

1 x 115 & 208-230 V, 50/60 Hz

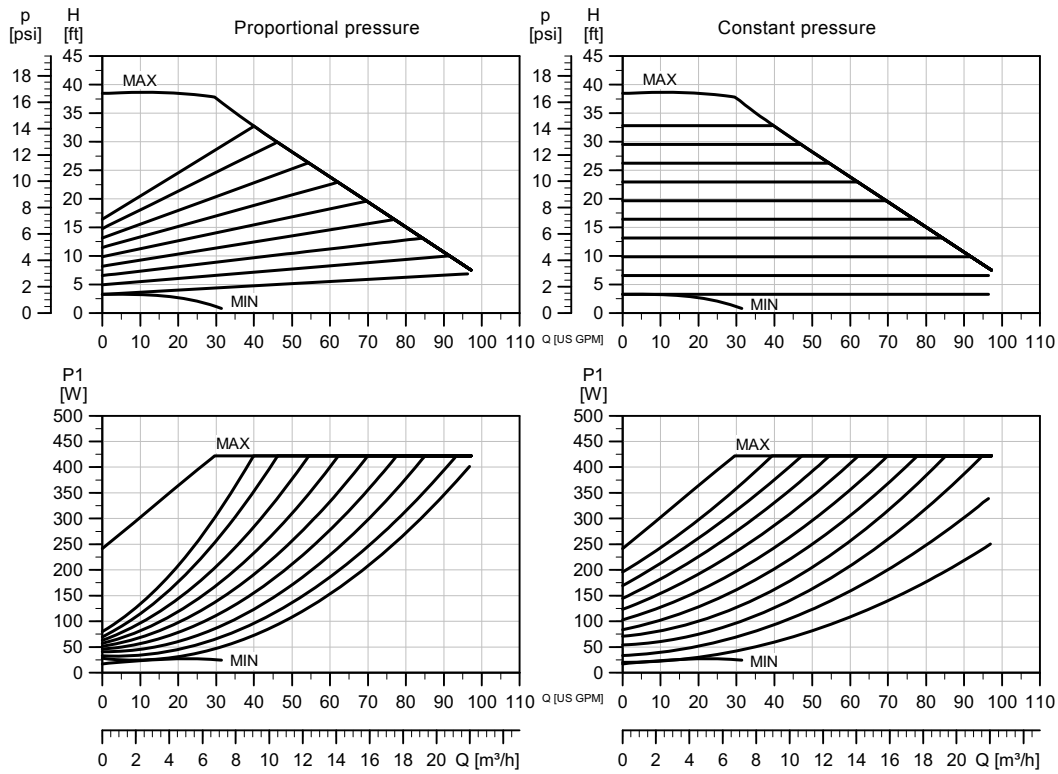

| Speed | I _{1/1} [A] 115 V | P1 [W] 115 V | I _{1/1} [A] 230 V | P1 [W] 230 V |
|-------|----------------------------|--------------|----------------------------|--------------|
| Min. | 0.26 | 16 | 0.19 | 16 |
| Max. | 3.88 | 442 | 1.95 | 440 |

The pump incorporates overload protection.

System pressure: Max. 175 psi [12 bar].
 Liquid temperature: 14 to 230 °F [-10 °C to +110 °C].
 Also available with: Stainless-steel pump housing, type N.
 Specific EEI: 0.18.

| Net weights lbs [kg] | Gross weights lbs [kg] | Ship. vol.ft ³ [m ³] |
|----------------------|------------------------|---------------------------------------------|
| 35 [15.9] | 41 [18.7] | 1.41 [0.04] |

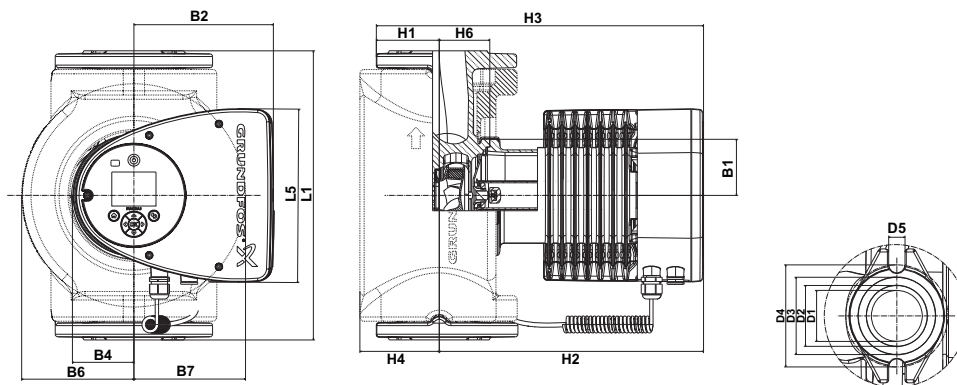

TM05 7651 14-13

| Pump type | Dimensions in. [mm] | | | | | | | | | | | | | | | | |
|---------------------|---------------------|------------|-----------|------------|-----------|------------|------------|-----------|-----------|----------|-----------|------------|----|-------------|----|-----------|-----------|
| | L1 | L5 | B1 | B2 | B4 | B6 | B7 | D1 | D2 | D3 | D4 | D5 | H1 | H2 | H3 | H4 | H6 |
| MAGNA3 40-120 F (N) | 8.5 [216] | 8.03 [204] | 3.31 [84] | 6.46 [164] | 2.87 [73] | 4.37 [111] | 4.37 [111] | 1.57 [40] | 1.93 [49] | 2.4 [60] | 3.15 [80] | 0.5 [12.8] | - | 11.97 [304] | - | 2.76 [70] | 1.97 [50] |

For product numbers, see page 46.

MAGNA3 40-180 F (N)

1 x 115 & 208-230 V, 50/60 Hz

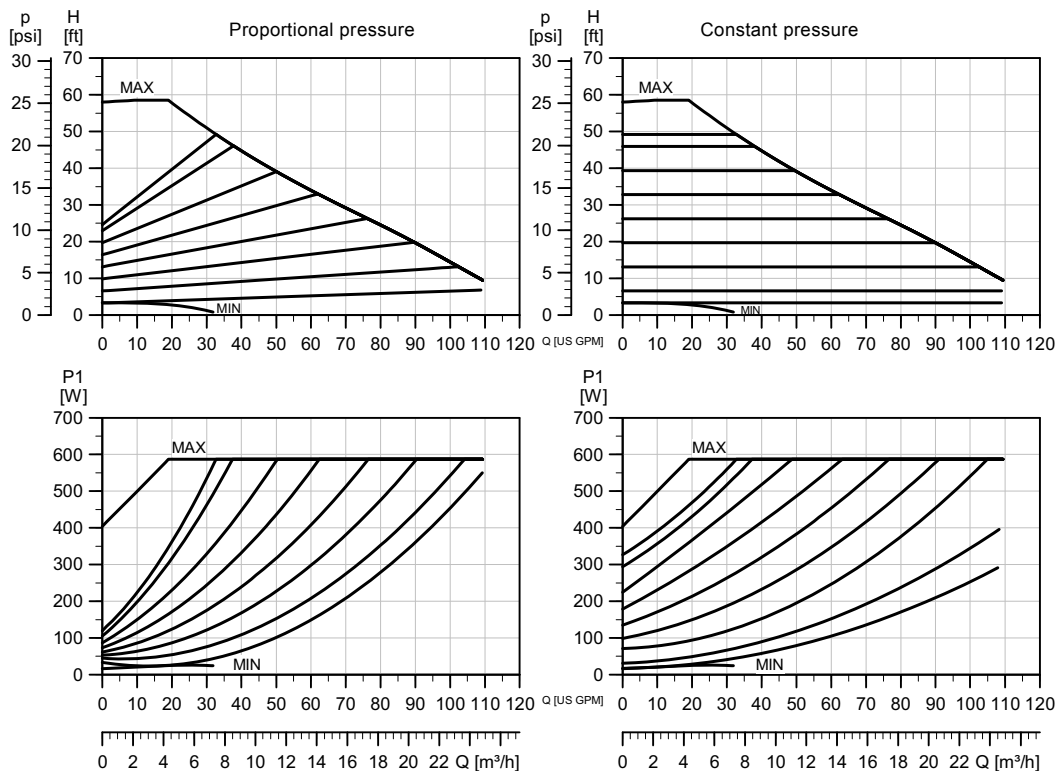

TM05 8105 1913

| Speed | $I_{1/1}$ [A] 115 V | P1 [W] 115 V | $I_{1/1}$ [A] 230 V | P1 [W] 230 V |
|-------|---------------------|--------------|---------------------|--------------|
| Min. | 0.26 | 16 | 0.18 | 16 |
| Max. | 5.39 | 614 | 2.68 | 607 |

The pump incorporates overload protection.

System pressure: Max. 175 psi [12 bar].
 Liquid temperature: 14 to 230 °F [-10 °C to +110 °C].
 Also available with: Stainless-steel pump housing, type N.
 Specific EEI: 0.18.

| Net weights lbs [kg] | Gross weights lbs [kg] | Ship. vol.ft ³ [m ³] |
|----------------------|------------------------|---------------------------------------------|
| 35 [15.9] | 41 [18.7] | 1.41 [0.04] |

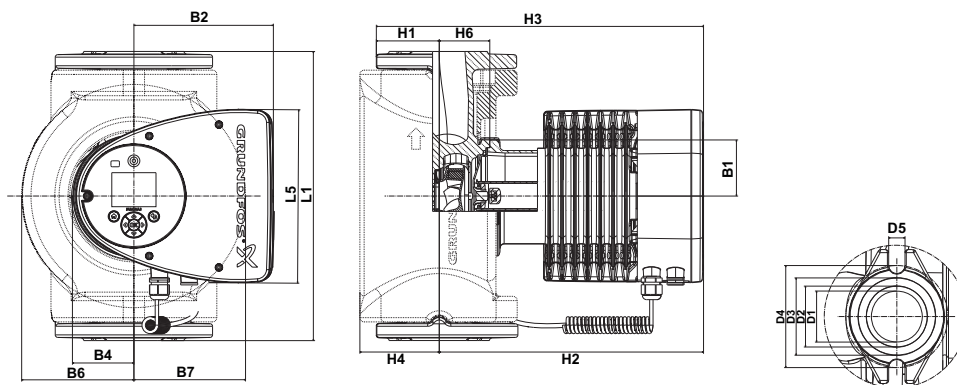

TM05 7651 1413

| Pump type | Dimensions in. [mm] | | | | | | | | | |
|---------------------|---------------------|------------|------------|------------|-------------|------------|------------|-----------|-----------|--|
| | L1 | L5 | B1 | B2 | B4 | B6 | B7 | D1 | D2 | |
| MAGNA3 40-180 F (N) | 8.5 [216] | 8.03 [204] | 3.31 [84] | 6.46 [164] | 2.87 [73] | 4.37 [111] | 4.37 [111] | 1.57 [40] | 1.93 [49] | |
| | D3 | D4 | D5 | H1 | H2 | H3 | H4 | H6 | | |
| | 2.4 [61] | 3.15 [80] | 0.5 [12.8] | - | 11.97 [304] | - | 2.76 [70] | 1.97 [50] | | |

For product numbers, see page 46.

MAGNA3 50-80 F (N)

1 x 115 & 208-230 V, 50/60 Hz

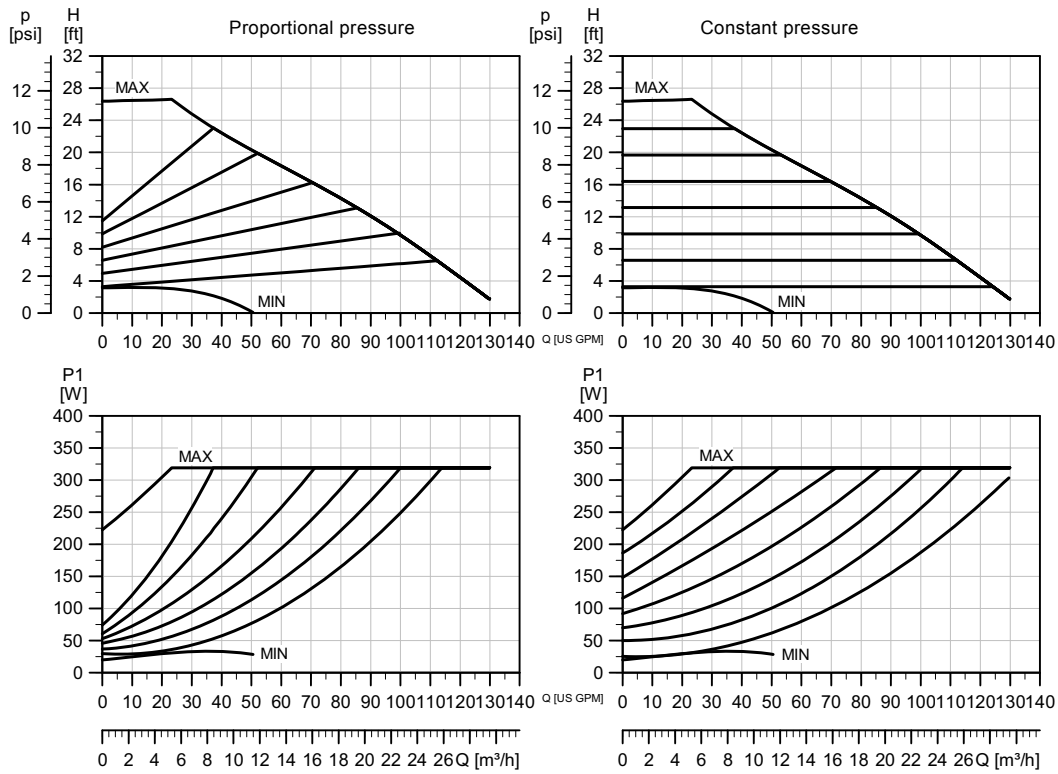

TM05 8106 1913

| Speed | $I_{1/1}$ [A] 115 V | P1 [W] 115 V | $I_{1/1}$ [A] 230 V | P1 [W] 230 V |
|-------|---------------------|--------------|---------------------|--------------|
| Min. | 0.31 | 18.5 | 0.22 | 18.5 |
| Max. | 2.81 | 318 | 1.46 | 325 |

System pressure: Max. 175 psi [12 bar].
 Liquid temperature: 14 to 230 °F [-10 °C to +110 °C].
 Also available with: Stainless-steel pump housing, type N.
 Specific EEI: 0.18.

The pump incorporates overload protection.

| Net weights lbs [kg] | Gross weights lbs [kg] | Ship. vol.ft ³ [m ³] |
|----------------------|------------------------|---------------------------------------------|
| 37 [17.0] | 45 [20.4] | 1.77 [0.05] |

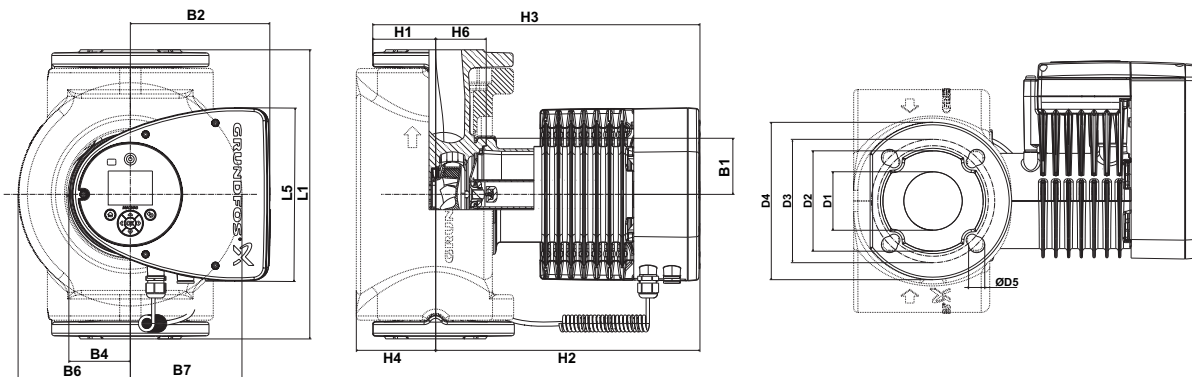

TM05 7652 1413

| Pump type | Dimensions in. [mm] | | | | | | | | | |
|--------------------|---------------------|------------|-------------------|------------|-------------|-------------|-----------|-----------|-----------|--|
| | L1 | L5 | B1 | B2 | B4 | B6 | B7 | D1 | D2 | |
| MAGNA3 50-80 F (N) | 9.45 [240] | 8.03 [204] | 3.31 [84] | 6.46 [164] | 2.87 [73] | 5 [127] | 5 [127] | 1.97 [50] | 3.90 [99] | |
| | D3 | D4 | D5 | H1 | H2 | H3 | H4 | H6 | | |
| | 4.33/4.92 [110/125] | 6.5 [165] | 0.55/0.75 [14/19] | 2.8 [71] | 12.05 [306] | 14.84 [377] | 3.82 [97] | 2.05 [52] | | |

For product numbers, see page 46.

MAGNA3 50-150 F (N)

1 x 115 & 208-230 V, 50/60 Hz

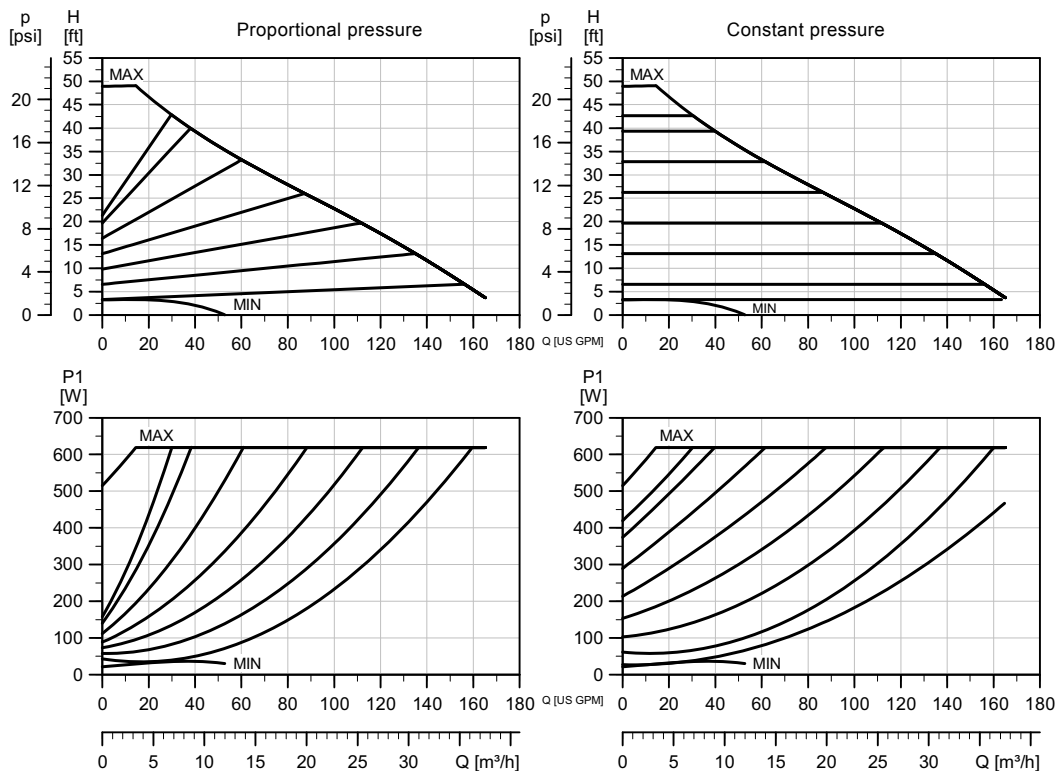

TM05 8107 1913

| Speed | I _{1/1} [A] 115 V | P1 [W] 115 V | I _{1/1} [A] 230 V | P1 [W] 230 V |
|-------|----------------------------|--------------|----------------------------|--------------|
| Min. | 0.31 | 18.5 | 0.23 | 18.5 |
| Max. | 5.54 | 630 | 2.78 | 630 |

System pressure: Max. 175 psi [12 bar].
 Liquid temperature: 14 to 230 °F [-10 °C to +110 °C].
 Also available with: Stainless-steel pump housing, type N.
 Specific EEI: 0.17.

The pump incorporates overload protection.

| Net weights lbs [kg] | Gross weights lbs [kg] | Ship. vol.ft³ [m³] |
|----------------------|------------------------|--------------------|
| 40 [18.3] | 49 [22.0] | 1.77 [0.05] |

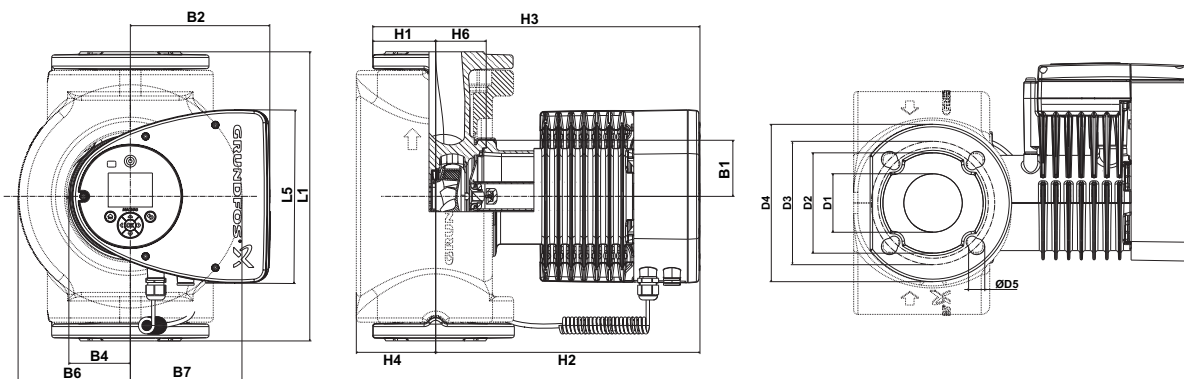

TM05 7652 1413

| Pump type | Dimensions in. [mm] | | | | | | | | |
|---------------------|---------------------|------------|-------------------|------------|-------------|------------|-----------|-----------|-----------|
| | L1 | L5 | B1 | B2 | B4 | B6 | B7 | D1 | D2 |
| MAGNA3 50-150 F (N) | 11.02 [280] | 8.03 [204] | 3.31 [84] | 6.46 [164] | 2.87 [73] | 5 [127] | 5 [127] | 1.97 [50] | 3.90 [99] |
| | D3 | D4 | D5 | H1 | H2 | H3 | H4 | H6 | |
| | 4.33/4.92 [110/125] | 6.5 [165] | 0.55/0.75 [14/19] | 2.83 [72] | 12.05 [306] | 14.9 [378] | 3.82 [97] | 2.05 [52] | |

For product numbers, see page 46.

MAGNA3 65-120 F (N)

1 x 115 & 208-230 V, 50/60 Hz

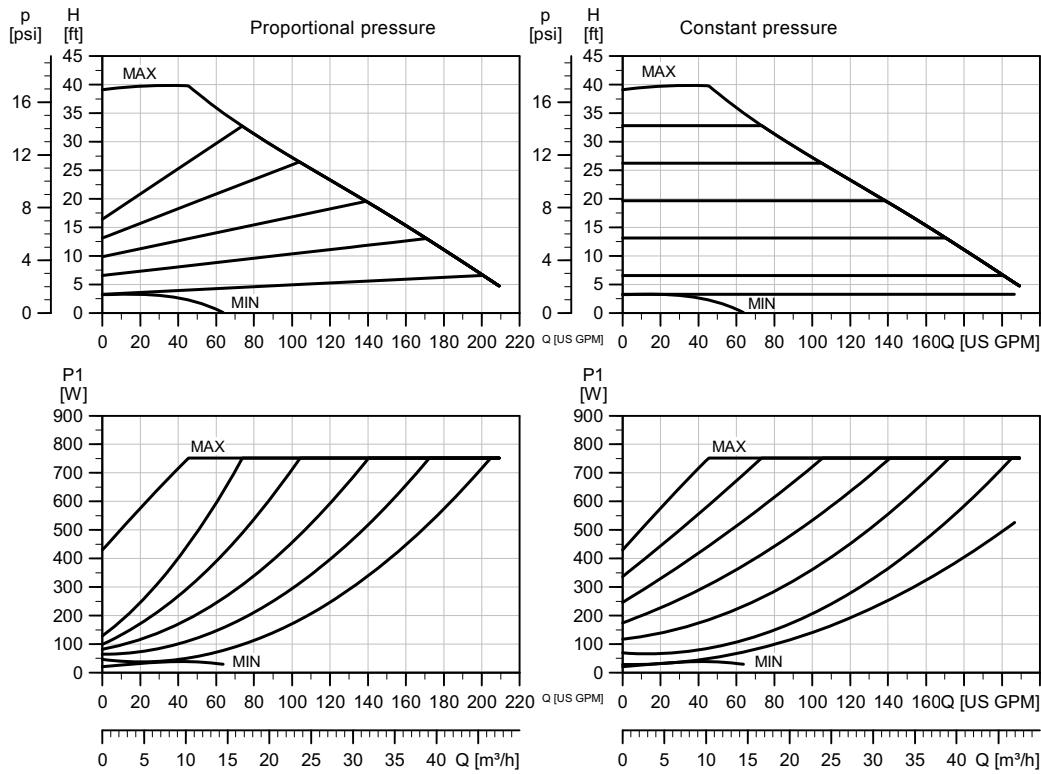

| Speed | I _{1/1} [A] 115 V | P1 [W] 115 V | I _{1/1} [A] 230 V | P1 [W] 230 V |
|-------|----------------------------|--------------|----------------------------|--------------|
| Min. | 0.36 | 20.5 | 0.18 | 20.5 |
| Max. | 6.67 | 772 | 3.38 | 769 |

System pressure: Max. 175 psi [12 bar].
 Liquid temperature: 14 to 230 °F [-10 °C to +110 °C].
 Also available with: Stainless-steel pump housing, type N.
 Specific EEI: 0.17.

The pump incorporates overload protection.

| Net weights lbs [kg] | Gross weights lbs [kg] | Ship. vol.ft ³ [m ³] |
|----------------------|------------------------|---------------------------------------------|
| 46 [21.0] | 54 [24.7] | 2.12 [0.06] |

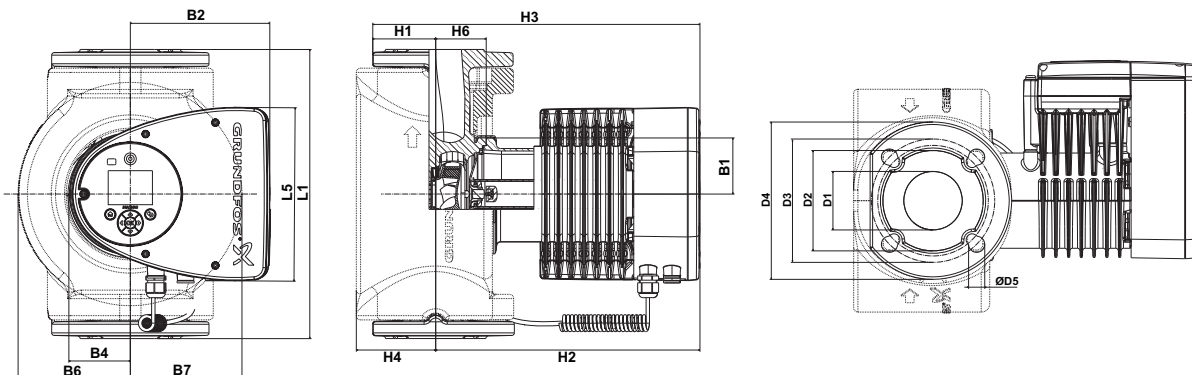

| Pump type | Dimensions in. [mm] | | | | | | | | | |
|---------------------|---------------------|------------|-------------------|------------|-------------|------------|------------|-----------|------------|--|
| | L1 | L5 | B1 | B2 | B4 | B6 | B7 | D1 | D2 | |
| MAGNA3 65-120 F (N) | 13.4 [340] | 8.03 [204] | 3.31 [84] | 6.46 [164] | 2.87 [73] | 5.24 [133] | 5.24 [133] | 2.56 [65] | 4.65 [118] | |
| | D3 | D4 | D5 | H1 | H2 | H3 | H4 | H6 | | |
| | 5.0/5.51 [127/140] | 7.28 [185] | 0.63/0.75 [16/19] | 2.91 [74] | 12.28 [312] | 15.2 [386] | 3.7 [94] | 2.32 [59] | | |

For product numbers, see page 46.

MAGNA3 65-150 F (N)

1 x 208-230 V, 50/60 Hz

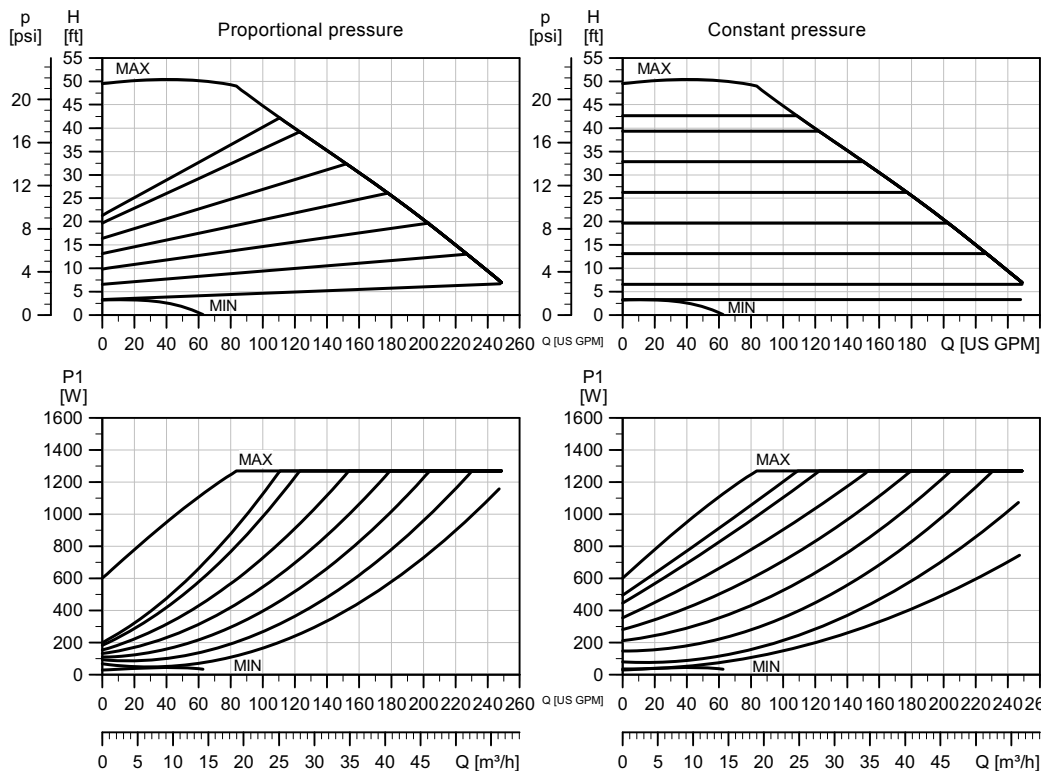

TM05 8109 1913

| Speed | P1 [W] | $I_{1/1}$ [A] |
|-------|--------|---------------|
| Min. | 29 | 0.30 |
| Max. | 1301 | 5.68 |

System pressure: Max. 175 psi [12 bar].
 Liquid temperature: 14 to 230 °F [-10 °C to +110 °C].
 Also available with: Stainless-steel pump housing, type N.
 Specific EEI: 0.17.

The pump incorporates overload protection.

| Net weights lbs [kg] | Gross weights lbs [kg] | Ship. vol.ft ³ [m ³] |
|----------------------|------------------------|---------------------------------------------|
| 53 [24.0] | 61 [27.8] | 2.12 [0.06] |

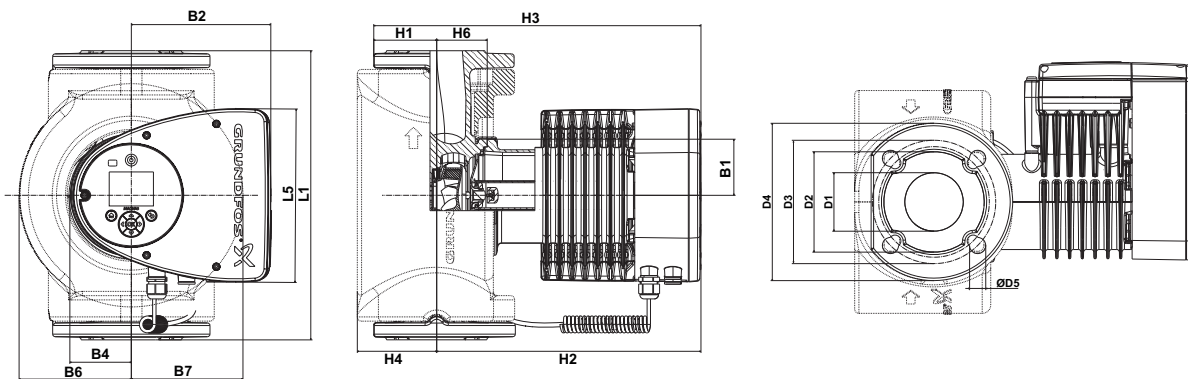

TM05 7652 1413

| Pump type | Dimensions in. [mm] | | | | | | | | | |
|---------------------|---------------------|------------|-------------------|------------|-------------|------------|------------|-----------|------------|--|
| | L1 | L5 | B1 | B2 | B4 | B6 | B7 | D1 | D2 | |
| MAGNA3 65-150 F (N) | 13.4 [340] | 8.03 [204] | 3.31 [84] | 6.46 [164] | 2.87 [73] | 5.24 [133] | 5.24 [133] | 2.56 [65] | 4.65 [118] | |
| | D3 | D4 | D5 | H1 | H2 | H3 | H4 | H6 | | |
| | 5.0/5.51 [127/140] | 7.28 [185] | 0.63/0.75 [16/19] | 2.91 [74] | 12.28 [312] | 15.2 [386] | 3.7 [94] | 2.32 [59] | | |

For product numbers, see page 46.

MAGNA3 D 65-150 F

1 x 208-230 V, 50/60 Hz

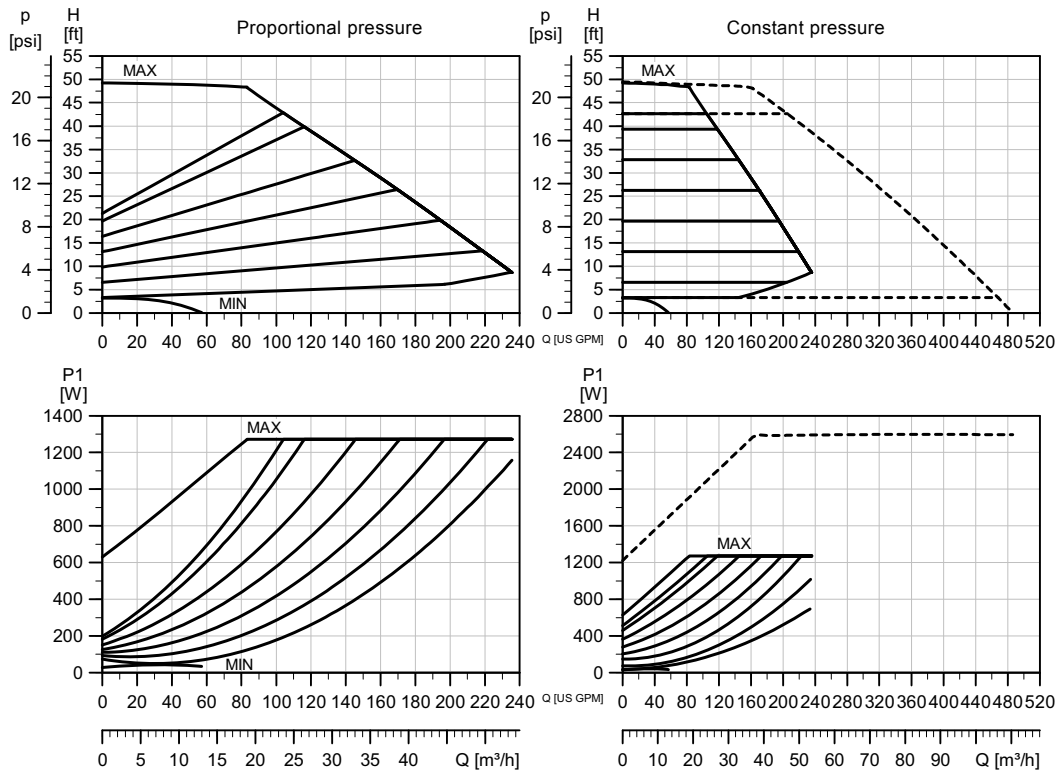

TM05 8112 1913

| Speed | P1 [W] | $I_{1/1}$ [A] |
|-------|--------|---------------|
| Min. | 29 | 0.30 |
| Max. | 1301 | 5.68 |

System pressure: Max. 175 psi [12 bar].
 Liquid temperature: 14 to 230 °F [-10 °C to +110 °C].
 Specific EEI: 0.17.

The pump incorporates overload protection.

| Net weights lbs [kg] | Gross weights lbs [kg] | Ship. vol.ft ³ [m ³] |
|----------------------|------------------------|---------------------------------------------|
| 98 [44.6] | 118 [53.7] | 2.12 [0.06] |

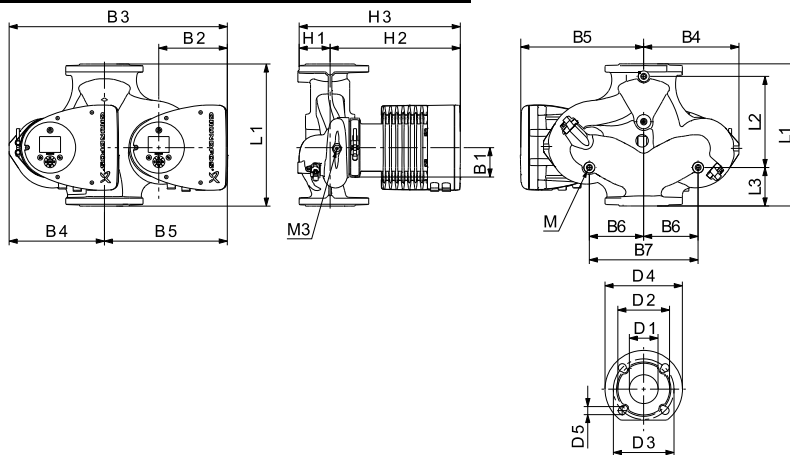

TM05 2205 3612

| Pump type | Dimensions [mm] | | | | | | | | | | |
|-------------------|-----------------|------------|---------------------|------------|------------|-----------|-------------|------------|-------------|-------------|-------------|
| | L1 | L2 | L3 | L4 | L5 | B1 | B3 | B4 | B5 | B6 | B7 |
| MAGNA3 D 65-150 F | 13.4 [340] | 8.58 [218] | 3.62 [92] | 3.62 [92] | 8.03 [204] | 3.31 [84] | 20.55 [522] | 8.98 [228] | 11.57 [294] | 5.12 [130] | 10.24 [260] |
| | D1 | D2 | D3 | D4 | D5 | D5 (2) | M | M1 | H1 | H2 | H3 |
| | 2.56 [65] | 4.69 [119] | 5.12/5.71 [130/145] | 7.28 [185] | 0.55 [14] | 0.75 [19] | M12 | Rp 1/4 | 3.03 [77] | 12.28 [312] | 15.31 [389] |

MAGNA3 80-100 F

1 x 208-230 V, 50/60 Hz

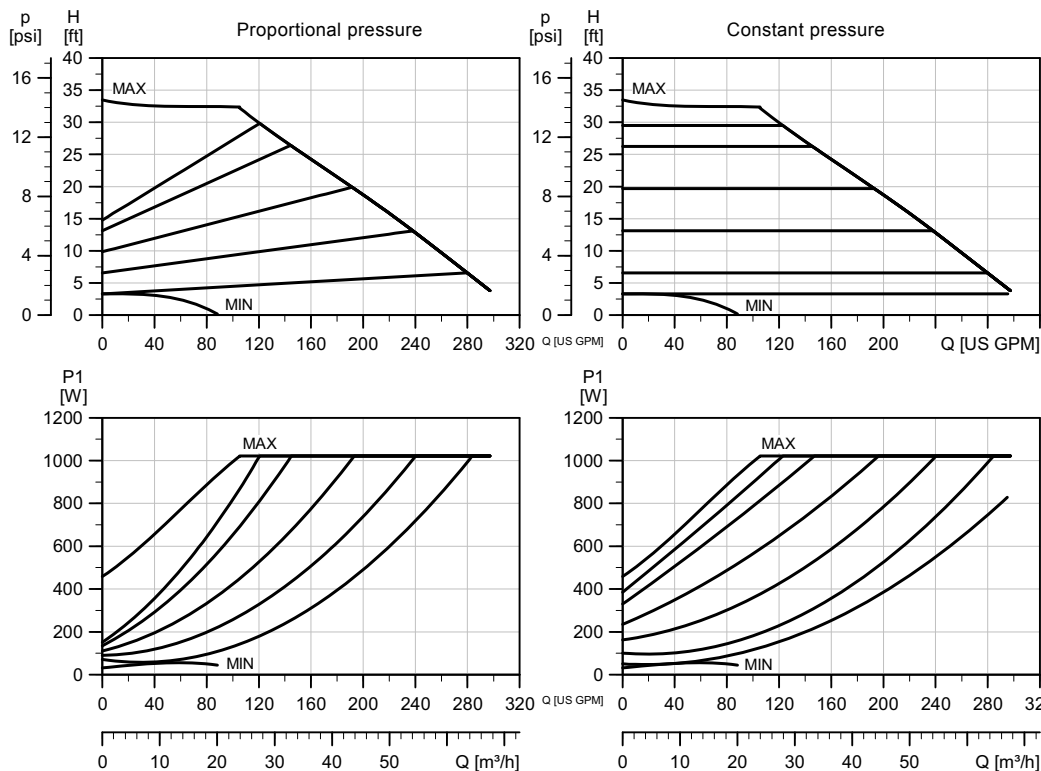

TM05 8110 1913

| Speed | P1 [W] | I _{1/1} [A] |
|-------|--------|----------------------|
| Min. | 31 | 0.32 |
| Max. | 1041 | 4.60 |

System pressure: Max. 175 psi [12 bar].
 Liquid temperature: 14 to 230 °F [-10 °C to +110 °C].
 Specific EEI: 0.17.

The pump incorporates overload protection.

| Net weights lbs [kg] | Gross weights lbs [kg] | Ship. vol.ft³ [m³] |
|----------------------|------------------------|--------------------|
| 63 [28.8] | 72 [32.6] | 2.47 [0.07] |

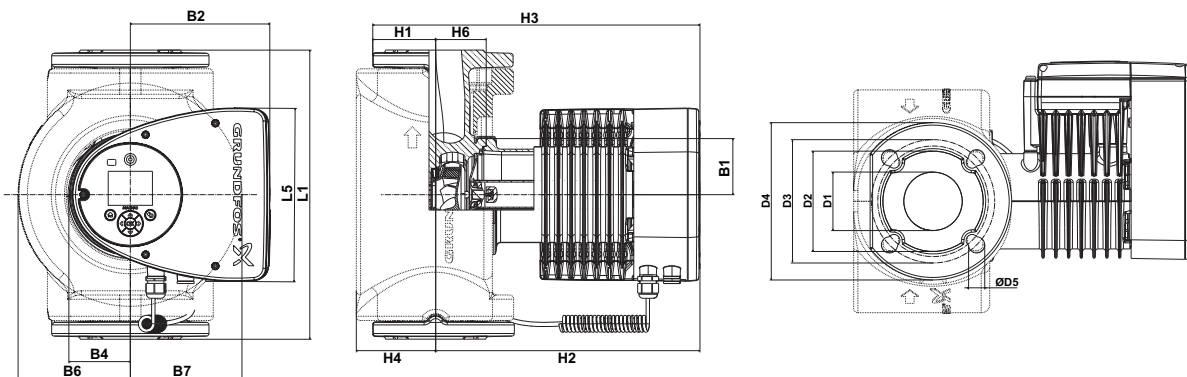

TM05 7652 1413

| Pump type | Dimensions in. [mm] | | | | | | | | |
|---------------------|---------------------|------------|-----------|------------|-------------|-------------|------------|-----------|-----------|
| | L1 | L5 | B1 | B2 | B4 | B6 | B7 | D1 | D2 |
| MAGNA3 80-100 F (N) | 14.17 [360] | 8.03 [204] | 3.31 [84] | 6.46 [164] | 2.87 [73] | 6.42 [163] | 6.42 [163] | 3.15 [80] | 5.2 [132] |
| | D3 | D4 | D5 | H1 | H2 | H3 | H4 | H6 | |
| | 5.91 [150] | 7.87 [200] | 0.75 [19] | 3.7 [94] | 12.52 [318] | 16.22 [412] | 4.53 [115] | 2.6 [66] | |

For product numbers, see page 46.

MAGNA3 D 80-100 F

1 x 208-230 V, 50/60 Hz

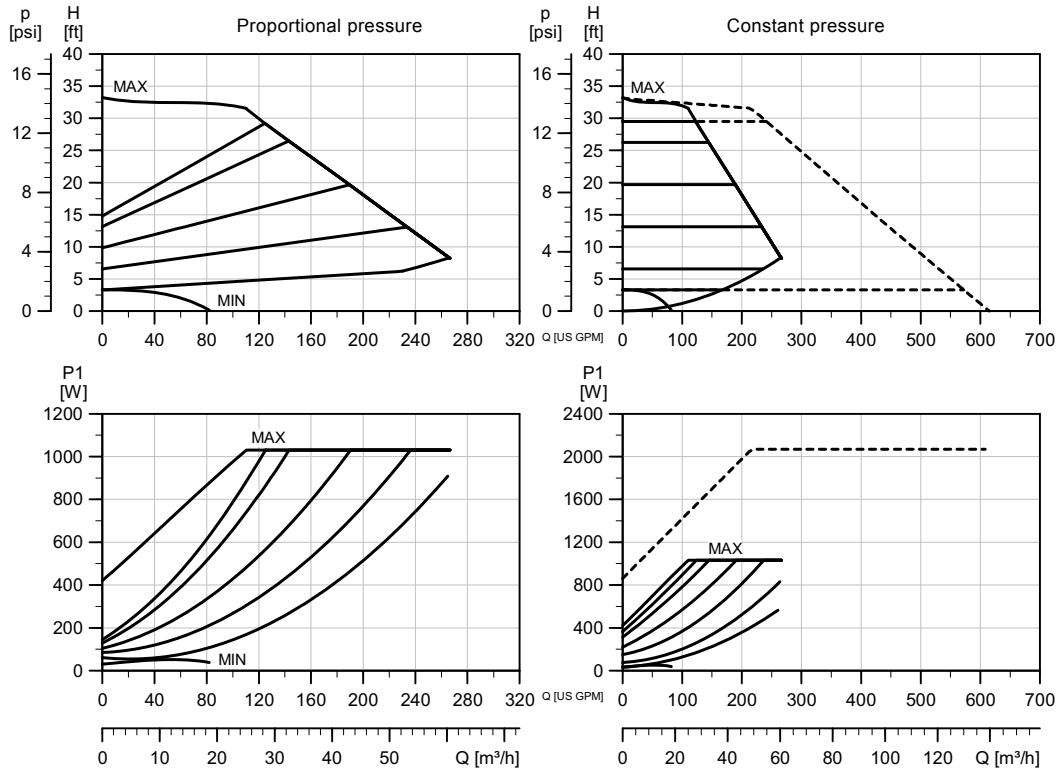

TM05 8113 1913

| Speed | P1 [W] | I _{1/1} [A] |
|-------|--------|----------------------|
| Min. | 32 | 0.32 |
| Max. | 1052 | 4.62 |

System pressure: Max. 175 psi [12 bar].
 Liquid temperature: 14 to 230 °F [-10 °C to +110 °C].
 Specific EEI: 0.17.

The pump incorporates overload protection.

| Net weights lbs [kg] | Gross weights lbs [kg] | Ship. vol.ft³ [m³] |
|----------------------|------------------------|--------------------|
| 114 [51.6] | 140 [63.4] | 2.47 [0.07] |

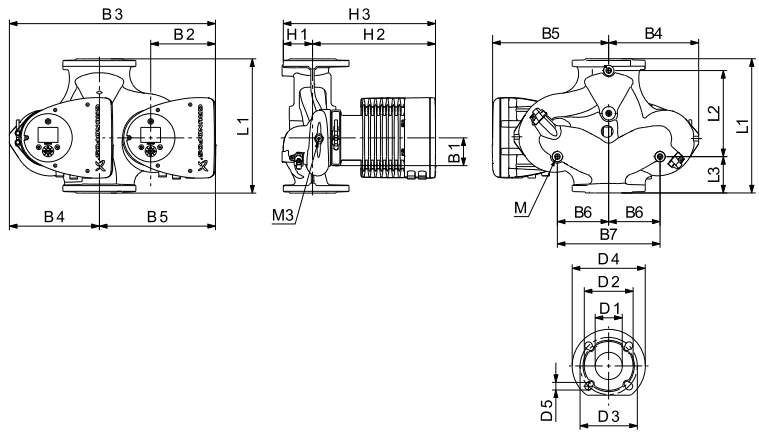

TM05 2205 3612

| Pump type | Dimensions [mm] | | | | | | | | | | |
|-------------------|-----------------|------------|------------|------------|------------|-----------|-------------|------------|-------------|-------------|-------------|
| | L1 | L2 | L3 | L4 | L5 | B1 | B3 | B4 | B5 | B6 | B7 |
| MAGNA3 D 80-100 F | 14.17 [360] | 8.58 [218] | 4.02 [102] | 4.02 [102] | 8.03 [204] | 3.31 [84] | 21.18 [538] | 9.61 [244] | 11.57 [294] | 5.12 [130] | 10.24 [260] |
| | D1 | D2 | D3 | D3 (2) | D4 | D5 | M | M1 | H1 | H2 | H3 |
| | 3.15 [80] | 5.04 [128] | 5.91 [150] | 6.30 [160] | 7.87 [200] | 0.75 [19] | M12 | Rp 1/4 | 3.82 [97] | 12.52 [318] | 16.34 [415] |

MAGNA3 100-120 F

1 x 208-230 V, 50/60 Hz

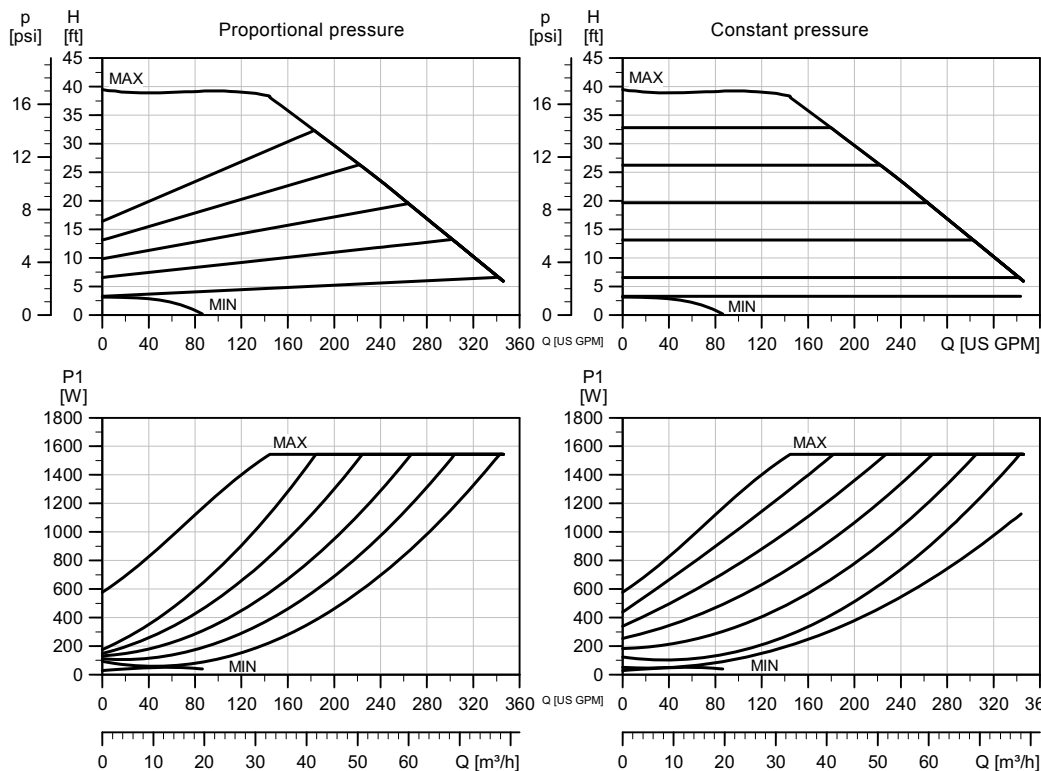

TM05 8111 1913

TM05 3761 1912

| Speed | P1 [W] | I _{1/1} [A] |
|-------|--------|----------------------|
| Min. | 31 | 0.32 |
| Max. | 1576 | 6.97 |

System pressure: Max. 175 psi [12 bar].
 Liquid temperature: 14 to 230 °F [-10 °C to +110 °C].
 Specific EEI: 0.17.

The pump incorporates overload protection.

| Net weights lbs [kg] | Gross weights lbs [kg] | Ship. vol.ft³ [m³] |
|----------------------|------------------------|--------------------|
| 73 [33.1] | 82 [37.0] | 3.53 [0.1] |

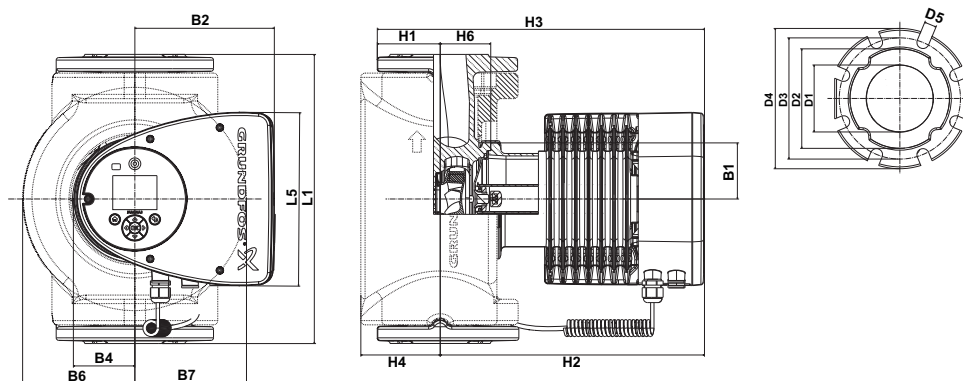

TM05 7650 1413

| Pump type | Dimensions in. [mm] | | | | | | | | |
|----------------------|---------------------|------------|-----------|------------|-------------|-------------|------------|------------|------------|
| | L1 | L5 | B1 | B2 | B4 | B6 | B7 | D1 | D2 |
| MAGNA3 100-120 F (N) | 17.72 [450] | 8.03 [204] | 3.31 [84] | 6.46 [164] | 2.87 [73] | 7.01 [178] | 7.01 [178] | 3.94 [100] | 6.14 [156] |
| | D3 | D4 | D5 | H1 | H2 | H3 | H4 | H6 | |
| | 7.52 [191] | 8.66 [220] | 0.75 [19] | 4.02 [102] | 12.99 [330] | 17.01 [432] | 4.72 [120] | 3.11 [79] | |

For product numbers, see page 46.

MAGNA3 D 100-120 F

1 x 208-230 V, 50/60 Hz

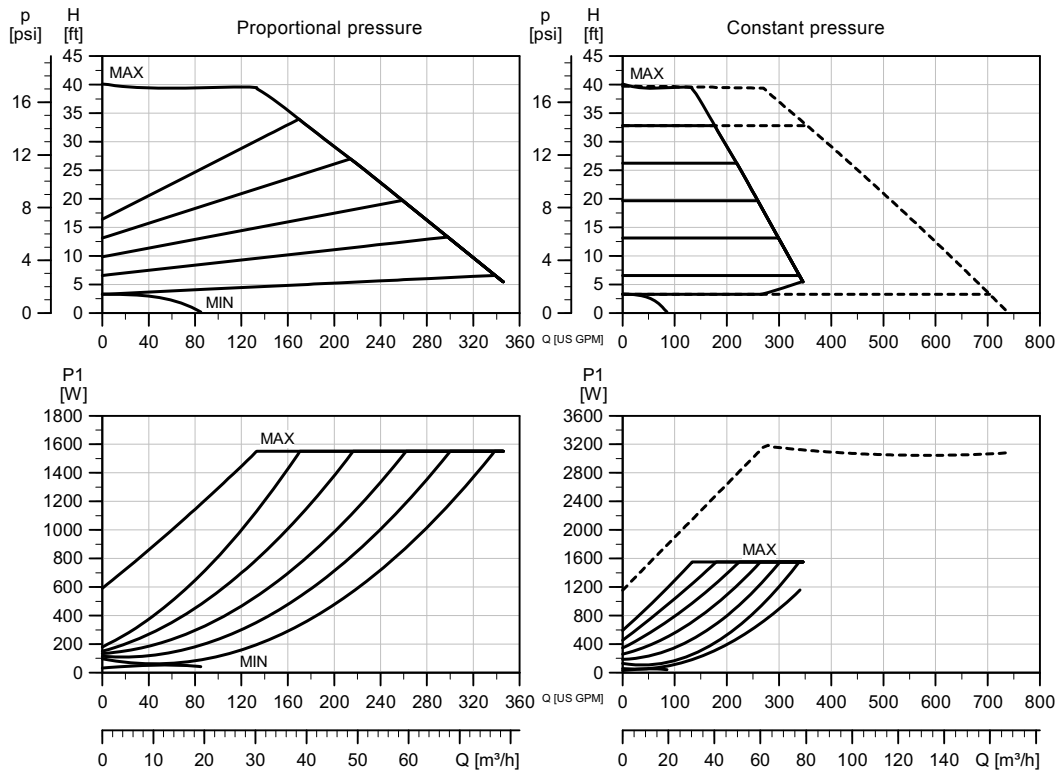

| Speed | P1 [W] | I _{1/1} [A] |
|-------|--------|----------------------|
| Min. | 35 | 0.35 |
| Max. | 1582 | 6.98 |

System pressure: Max. 175 psi [12 bar].
 Liquid temperature: 14 to 230 °F [-10 °C to +110 °C].
 Specific EEI: 0.17.

The pump incorporates overload protection.

| Net weights lbs [kg] | Gross weights lbs [kg] | Ship. vol.ft³ [m³] |
|----------------------|------------------------|--------------------|
| 133 [60.4] | 161 [72.8] | 3.53 [0.1] |

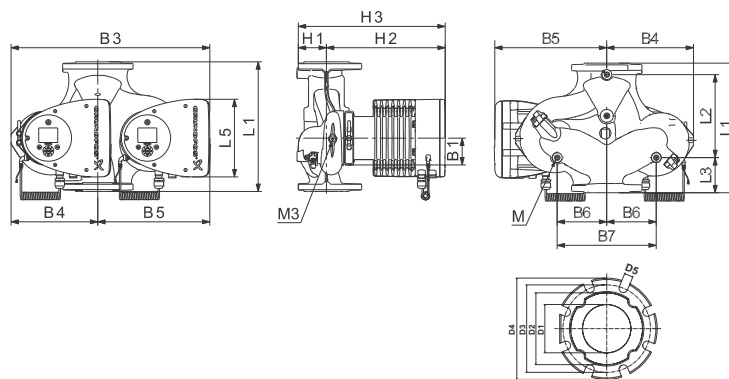

TM05 7701 1513

| Pump type | Dimensions [mm] | | | | | | | | | | |
|--------------------|-----------------|------------|------------|------------|------------|-----------|-------------|------------|-------------|-------------|-------------|
| | L1 | L2 | L3 | L4 | L5 | B1 | B3 | B4 | B5 | B6 | B7 |
| MAGNA3 D 100-120 F | 17.72 [450] | 9.57 [243] | 5.79 [147] | 5.79 [147] | 8.03 [204] | 3.31 [84] | 21.69 [551] | 9.92 [252] | 11.77 [299] | 5.31 [135] | 10.63 [270] |
| | D1 | D2 | D3 | D4 | D5 | M | M1 | H1 | H2 | H3 | |
| | 3.94 [100] | 6.3 [160] | 6.69 [170] | 8.66 [220] | 0.75 [19] | M12 | Rp 1/4 | 4.06 [103] | 12.99 [330] | 17.09 [434] | |

10. Product numbers

MAGNA3

| Single-head pump | Cast iron | | Stainless steel | |
|----------------------|-----------|----------|-----------------|----------|
| | 115 V | 208-230V | 115 V | 208-230V |
| MAGNA3 40-80 F (N) | 98126800 | 98126828 | 98126802 | 98126830 |
| MAGNA3 40-120 F (N) | 98126804 | 98126832 | 98126806 | 98126834 |
| MAGNA3 40-180 F (N) | 98126808 | 98126836 | 98126810 | 98126838 |
| MAGNA3 50-80 F (N) | 98126812 | 98126840 | 98126814 | 98126842 |
| MAGNA3 50-150 F (N) | 98126816 | 98126844 | 98126818 | 98126846 |
| MAGNA3 65-120 F (N) | 98124696 | 98126848 | 98124702 | 98126850 |
| MAGNA3 65-150 F (N) | | 98126852 | | 98126854 |
| MAGNA3 80-100 F (N) | | 98126856 | | 98126858 |
| MAGNA3 100-120 F (N) | | 98126860 | | 98126862 |

| Single-head pump | Cast iron | | Stainless steel | |
|--------------------|-----------|----------|-----------------|----------|
| | 115 V | 208-230V | 115 V | 208-230V |
| MAGNA3 D 65-150 F | | 98126863 | | |
| MAGNA3 D 80-100 F | | 98126864 | | |
| MAGNA3 D 100-120 F | | 98126865 | | |

External sensors

| Sensor | Type | Measuring range °F [°C] | Power supply [VDC] | Transmitter output [ma] | Process connection | Product number |
|--------------------------|--------|-------------------------------|--------------------|-------------------------|-----------------------------------|----------------|
| External Temperature Kit | DPI +T | -22 to 248 °F [-30 to 120 °C] | 11 to 30 | 4 to 20 | G $\frac{1}{2}$ --G $\frac{1}{2}$ | 98477669 |
| | | | | | G $\frac{1}{2}$ --G1/4 | 98477668 |

| Sensor | Type | Measuring range psi | Measuring range [bar] | Transmitter output [mA] | Power supply [VDC] | Process connection | Product number |
|----------------------|------|---------------------|-----------------------|-------------------------|--------------------|--------------------|----------------|
| Pressure transmitter | RPI | 0 - 9 | [0 - 0.6] | 4 to 20 | 12-to 30 | G 1/2 | 96611522 |
| | | 0 - 14 | [0 - 1.0] | | | | 96611523 |
| | | 0 - 23 | [0 - 1.6] | | | | 96611524 |
| | | 0 - 36 | [0 - 2.5] | | | | 96611525 |

Blanking flange

A blanking flange is used to blank off the opening when one of the pumps of a twin-head pump is removed for service to enable uninterrupted operation of the other pump.

| Blanking flange | Product number |
|-----------------|----------------|
| All pumps | 98159372 |

11. Further product information

WebCAPS

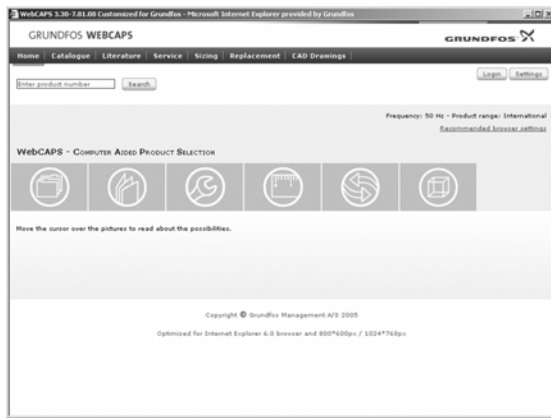

WebCAPS is a **Web-based Computer Aided Product Selection** program available on www.grundfos.com.

WebCAPS contains detailed information on more than 220,000 Grundfos products in more than 30 languages.

Information in WebCAPS is divided into six sections:

- Catalog
- Literature
- Service
- Sizing
- Replacement
- CAD drawings.

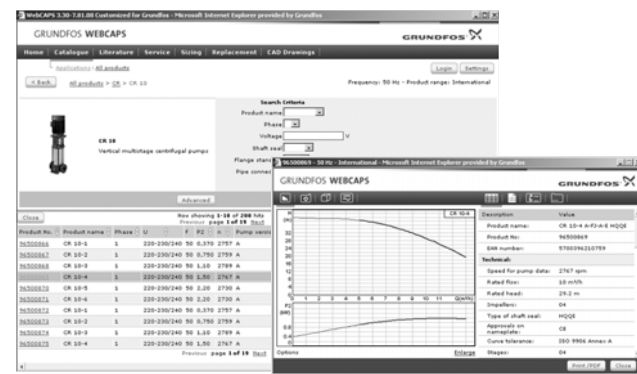

Catalog

Based on fields of application and pump types, this section contains the following:

- technical data
- curves (QH, Eta, P1, P2, etc.) which can be adapted to the density and viscosity of the pumped liquid and show the number of pumps in operation
- product photos
- dimensional drawings
- wiring diagrams
- quotation texts, etc.

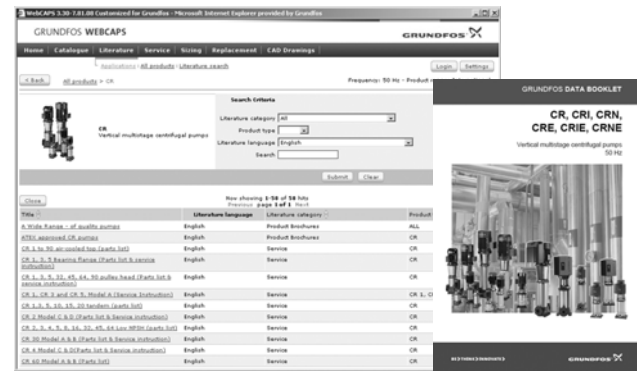

Literature

This section contains all the latest documents of a given pump, such as

- data booklets
- installation and operating instructions
- service documentation, such as Service kit catalogue and Service kit instructions
- quick guides
- product brochures.



Service

This section contains an easy-to-use interactive service catalogue. Here you can find and identify service parts of both existing and discontinued Grundfos pumps.

Furthermore, the section contains service videos showing you how to replace service parts.



Sizing

This section is based on different fields of application and installation examples and gives easy step-by-step instructions in how to size a product:

- Select the most suitable and efficient pump for your installation.
- Carry out advanced calculations based on energy, consumption, payback periods, load profiles, life cycle costs, etc.
- Analyse your selected pump via the built-in life cycle cost tool.
- Determine the flow velocity in wastewater applications, etc.



Replacement

In this section you find a guide to selecting and comparing replacement data of an installed pump in order to replace the pump with a more efficient Grundfos pump. The section contains replacement data of a wide range of pumps produced by other manufacturers than Grundfos.

Based on an easy step-by-step guide, you can compare Grundfos pumps with the one you have installed on your site. When you have specified the installed pump, the guide will suggest a number of Grundfos pumps which can improve both comfort and efficiency.

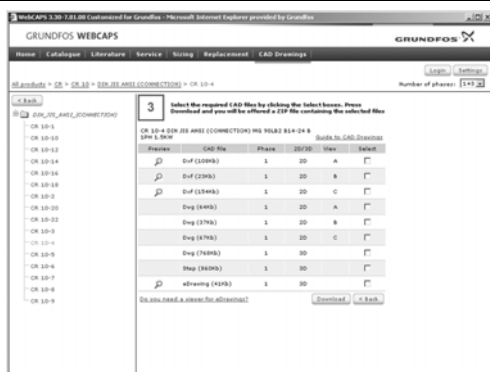

CAD drawings

In this section, it is possible to download 2-dimensional (2D) and 3-dimensional (3D) CAD drawings of most Grundfos pumps.

These formats are available in WebCAPS:

- 2-dimensional drawings:
- .dxf, wireframe drawings
 - .dwg, wireframe drawings.
- 3-dimensional drawings:
- .dwg, wireframe drawings (without surfaces)
 - .stp, solid drawings (with surfaces)
 - .eprt, E-drawings.

WinCAPS



Fig. 54 WinCAPS DVD

WinCAPS is a **Windows-based Computer Aided Product Selection** program containing detailed information on more than 220,000 Grundfos products in more than 30 languages.

The program contains the same features and functions as WebCAPS, but is an ideal solution if no internet connection is available.

WinCAPS is available on DVD and updated once a year.

GO CAPS

Mobile solution for professionals on the GO!



CAPS functionality on the mobile workplace.



Subject to alterations.

| |
|----------------------|
| 98439208 0513 |
|----------------------|

| |
|--------------|
| ECM: 1116022 |
|--------------|

GRUNDFOS Pumps Corporation

17100 West 118th Terrace
Olathe, Kansas 66061
Phone: +1-913-227-3400
Telefax: +1-913-227-3500

GRUNDFOS Canada Inc.

2941 Brighton Road
Oakville, Ontario L6H 6C9
Canada
Phone: +1-905 829 9533
Telefax: +1-905 829 9512

Bombas GRUNDFOS de Mexico S.A. de C.V.

Boulevard TLC No. 15
Parque Industrial Stiva Aeropuerto
Apodaca, N.L. Mexico 66600
Phone: +52-81-8144 4000
Telefax: +52-81-8144 4010

GRUNDFOS 